

25KHz Sensors



Available as:

- Standard-Range
- Mid-Range
- Long-range

Standard Range
0.6 m to 25 m (2 ft to 82 ft)

Mid-Range
0.6 m to 30 m (2 ft to 98 ft)

Long Range
0.6 m to 40 m (2 ft to 131 ft)

Sensors' Materials

Aluminum –

- Customarily used in Solid applications
- High sensitivity to echoes
- Not applicable in highly acid or alcoholic environments

Stainless steel –

- For liquid applications
- High resistance in acid and alcoholic environments
- Less sensitive to echoes (in solid application)

Aluminum Teflon coated –

- Designed for complex environments with problematic echo, such as non-conductive vapors or liquids
- Good performance in problematic applications
- Applicable in acid or alcoholic environment



INGENIEROS ASOCIADOS DE CONTROL, S. L.

Tel. 913831390

comercial@iac-sl.es

25KHz Sensors

25 kHz Standard Range and Mid-range Sensor

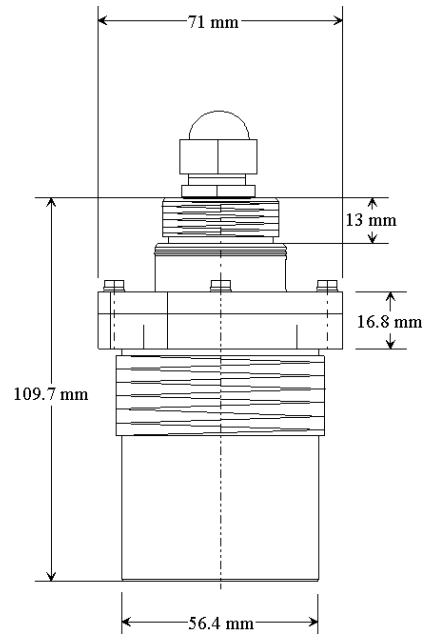

25 kHz Long Range Sensor

