



INGENIEROS ASOCIADOS DE CONTROL S.L.

Tel.: 913831390  
comercial@iac-sl.es

# TT301

SMART TEMPERATURE TRANSMITTERS



smar



- ✓ Single unit accepts signal from:
  - Standart RTDs and Thermocouples
  - Single ended or differential sensing
  - mV signals from radiation pyrometers, load cells, etc.
  - Ohm signals from position indicators, etc.
- ✓ Built-in thermocouples and RTDs linearization
- ✓ 0.02% basic accuracy
- ✓ Excellent long term stability due to auto-zero at the input circuit
- ✓ Signal isolation
- ✓ High EMI-RFI immunity
- ✓ Two wire, 4-20 mA output plus direct digital communication (HART Protocol)
- ✓ Remote configuration via Hand-Held Terminal or via PC
- ✓ On-line and off-line configuration
- ✓ Special 16-point sensor characterization
- ✓ Optional PID control function with programmable setpoint curve
- ✓ Explosion proof and weather proof
- ✓ Intrinsically safe

The Smar **TT301** is a powerful and extremely versatile Smart temperature transmitter, which can be used with practically all relevant temperature sensors as well as with load cells, resistance position indicators, etc.

The same unit can be used for different measuring ranges and many types of sensors such as various thermocouples and RTDs, mV or Ohm (see table on Functional Specifications). Hence, the plant can be standardized using the TT301 in measurements where different types of conventional (analog) transmitters previously where necessary. This drastically reduces calibration and maintenance time, spare part requirements and training. It also allows the TT301 to be purchased before measurement and control parameters are known.

Input/Output isolation with high RFI and EMI immunity are standard features.

The TT301 transmitter is suitable for direct field installation, being weather proof and explosion proof, as well as intrinsically safe, for use in hazardous areas.

As a two-wire temperature transmitter the TT301 generates a 4-20 mA output signal proportional to the desired temperature range.

Together with the 4-20 mA signal on the same pair of wires, there is a digital signal for communication.

With a Hand-Held Terminal and using digital communication the TT301 can be configured and reranged locally or remotely. The Hand-Held Terminal can be connected in any point of the 4-20 mA line.

The TT301 can operate as a conventional analog transmitter. The user may choose not to use the digital communication capability if he so desires.

A unique feature of the TT301 is the optional PID control capability. With one instruction via Hand-Held Terminal or the local adjustment, the transmitter start working as transmitter plus controller. The 4-20 mA is the output of a PID controller whose process variable is the measured temperature and the setpoint is adjusted by the operator or a configurable setpoint generator.

The output signal can be connected to a final control element, as a control valve, while the digital part of the signal inform the process variable, output, the setpoint, and all other transmitter and PID parameters.

The TT301 operates as shown on the block diagram.

## Main Processor Assembly

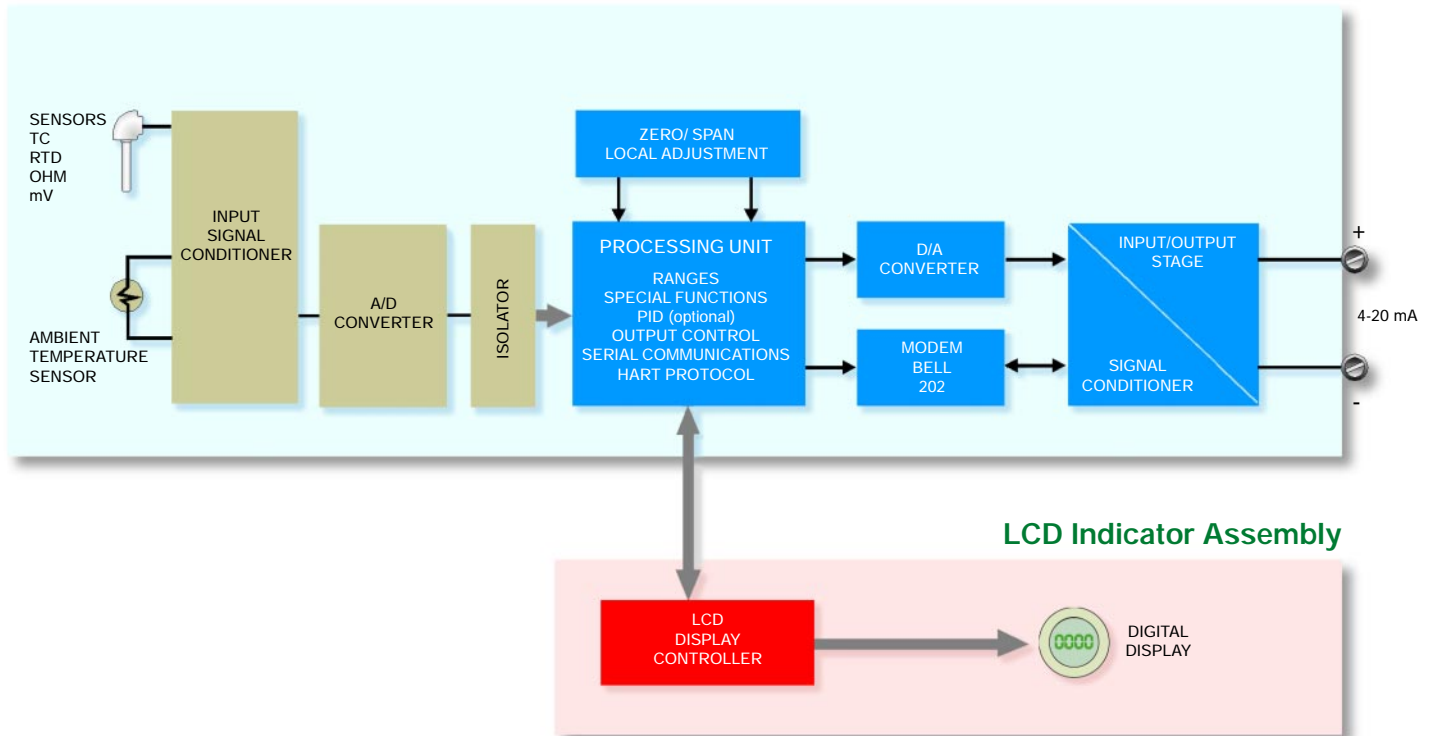

The **TT301** can be configured by a Hand-Held Terminal or PC (Personal Computer) using the software CONF301, together with a SMAR HI311 interface (HART/RS232C).

The CONF301 is a configuration tool running under the application MS Windows operating system.

Configuration, reranging, PID adjustment (optional), setpoint changing, etc. are performed by both the Hand-Held Terminal and CONF301, when connected in parallel to any point of the 4-20 mA line. A single Hand-Held Terminal or computer can be used for configuration any number of transmitters.

The local adjustment using the magnetic screwdriver allows, besides the zero and span adjustments, setpoint and other controller functions changing, calibration, etc.

All these features also result in short engineering and start-up times.

CONF301 - CONFIGURATION SOFTWARE

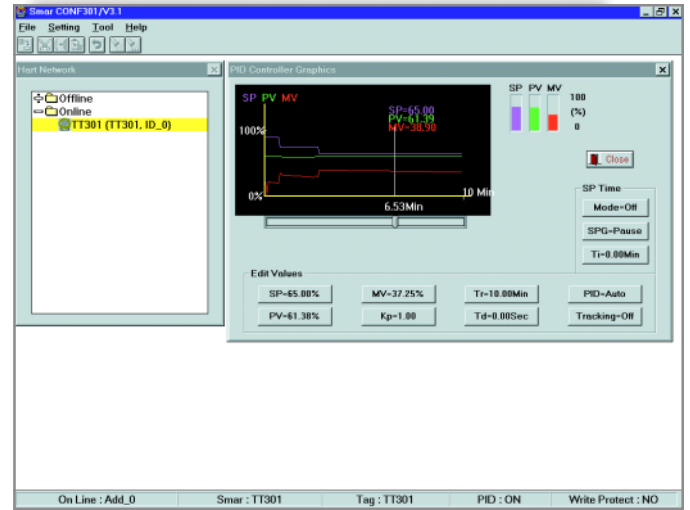

## WIRING CONNECTION

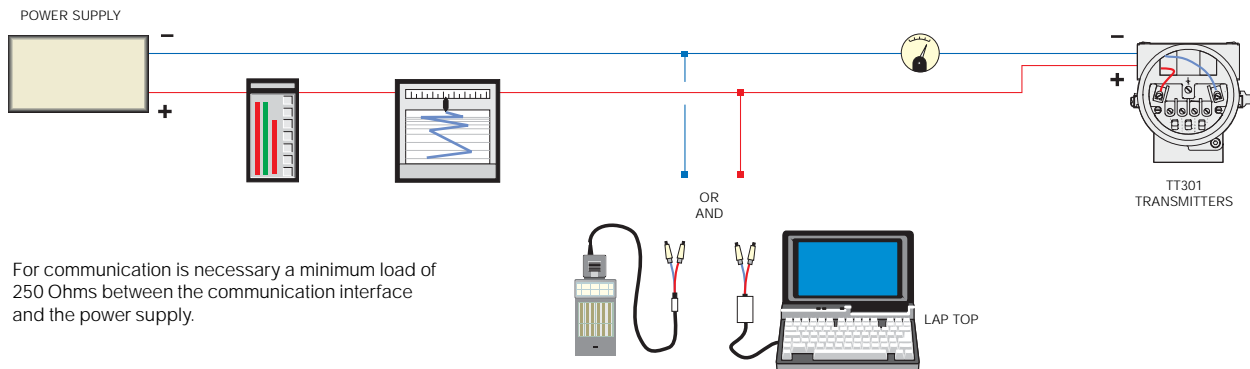

For communication is necessary a minimum load of 250 Ohms between the communication interface and the power supply.



## Working as a Conventional Transmitter

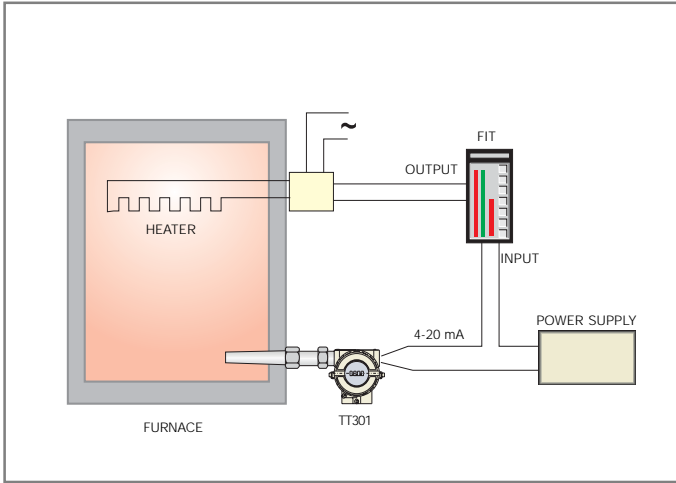

## Working as a Local Controller with PID (optional)

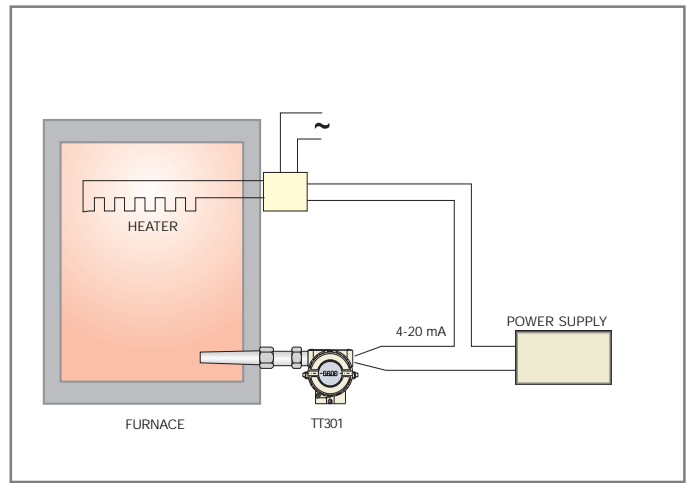

When the **TT301** is configured as a controller it replaces a separate controller, cutting cost and increasing reliability.

Since the sensor and actuator are normally located relatively close to each other compared to a controller in the control room, a lot of wiring can be saved.

## Working in a Multidrop Configuration with Computer Supervision from the Control Room

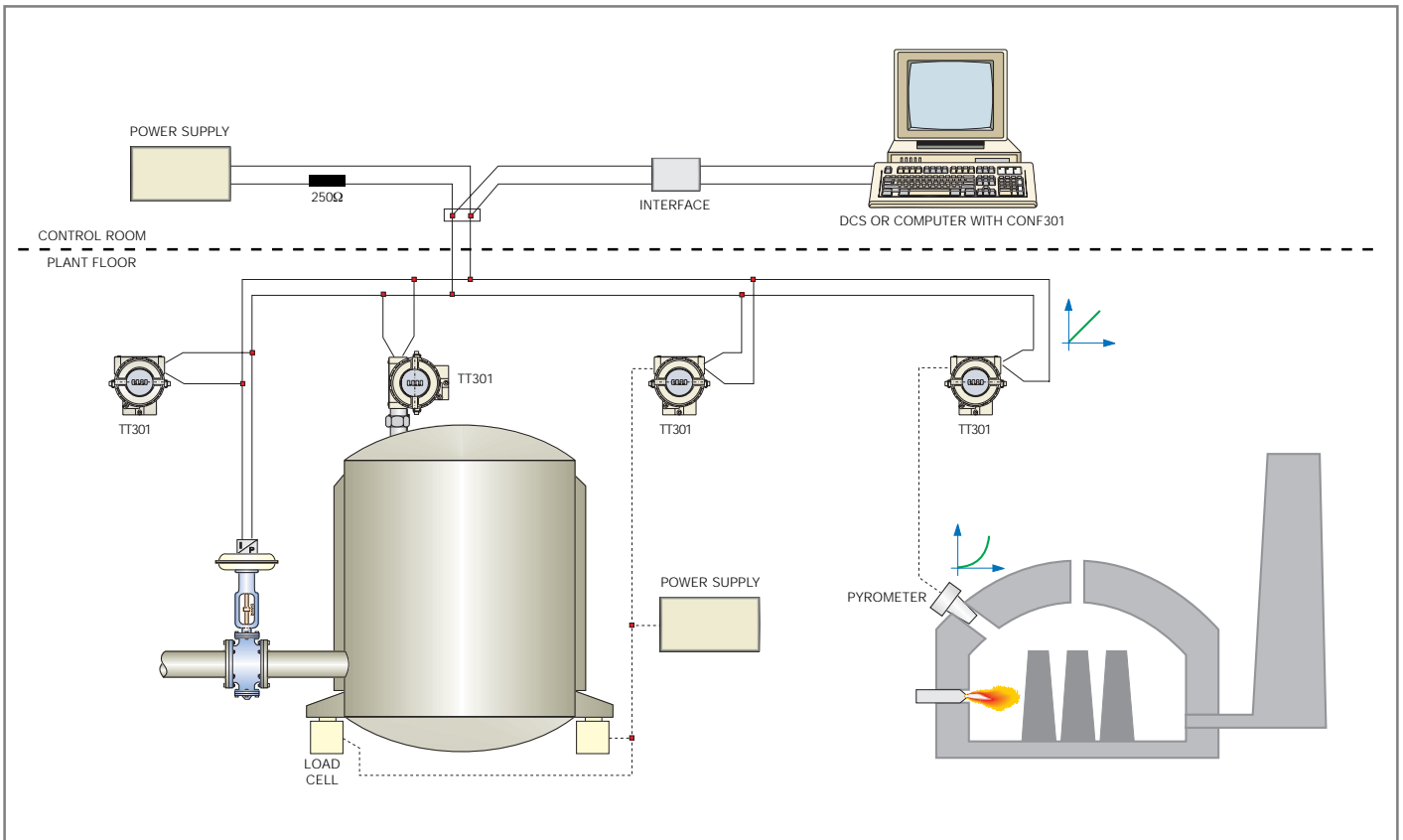

## Functional Specifications

### Inputs

Options see table.

### Output Signal

Two-wire, 4-20 mA with superimposed digital communication HART Protocol Version 5.1/Transmitter/Poll-Response mode/Common 4-20 mA).

### Power Supply

12 to 45 Vdc

### Load Limitation

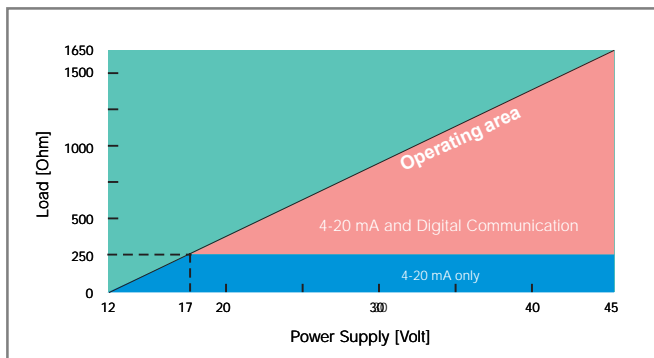

### Indication

Optional 4½-digit LCD indicator.

### Hazardous Location Certification

Explosion proof, weather proof and intrinsically safe CENELEC, CSA and FM standards.

### Zero and Span Adjustment

Noninteractive, by Hand-Held Terminal or local adjustment.

### Temperature Limits

Operation: -40 to 85 °C (-40 to 185 °F)  
 Storage: -40 to 120 °C (-40 to 248 °F)  
 Digital Display: -10 to 60 °C (14 to 140 °F) operation  
 -40 to 85 °C (-40 to 185 °F) without damage.

### Loss of Input (Burnout)/Failure Alarm

In case of sensor burnout or circuit failure, the self diagnostics drives the output to 3.9 or to 21.0 mA, according to the user's choice.

### Humidity Limits

10 to 100% RH

### Turn-on Time

Approximately 10 seconds.

### Update Time

Approximately 0.5 second.

### Damping

Adjustable 0-32 seconds.

## Configuration

This is done by an external Hand-Held Terminal, that communicates with the transmitter remote or locally using HART Protocol. Locally the magnetic tool can be used as well. The magnetic tool can configure the majority of the items provided the transmitter is fitted with a display.

## Performance Specifications

### Accuracy

See the following tables.

### Ambient Temperature Effect

For a 10 °C variation:

mV (-6...22 mV, TC (NBS: B, R, S, T):  $\pm 0.03\%$  of the input millivoltage or 0.002 mV whichever is greater.

mV (-10...100 mV), TC (NBS: E, J, K, N; DIN: L, U):  $\pm 0.03\%$  of the input millivoltage or 0.01 mV whichever is greater.

mV (-50...500 mV):  $\pm 0.03\%$  of the input millivoltage or 0.05 mV whichever is greater.

Ohms (0...100 $\Omega$ ), RTD (GE: Cu10):  $\pm 0.03\%$  of the input resistance or 0.01 $\Omega$  whichever is greater.

Ohms (0...400 $\Omega$ ), RTD (DIN: Ni120; IEC: Pt50, Pt100; JIS: Pt50, Pt100):  $\pm 0.03\%$  of the input resistance or 0.04 $\Omega$  whichever is greater.

Ohms (0...2000 $\Omega$ ), RTD (IEC: Pt500):  $\pm 0.03\%$  of the input resistance or 0.2 $\Omega$  whichever is greater.

TC: cold-junction compensation rejection 60:1 (Reference: 25.0 $\pm$ 0.3 °C).

### Power Supply Effect

$\pm 0.005\%$  of calibrated span per volt.

### Vibration Effect

Meets SAMA PMC 31.1

### Electro-Magnetic Interference Effect

Designed to comply with IEC 801

## Physical Specifications

### Electrical Connection

½ - 14 NPT, Pg 13,5 or M20 x 1,5 metric

### Material of Construction

Injected low copper aluminum with polyester painting or 316 Stainless Steel housing, with Buna N O-Rings on cover (NEMA 4X, IP67).

### Mounting

Can be attached directly to the sensor. With an optional bracket can be installed on a 2" pipe or fixed on a wall or panel.

### Weight

Without display and mounting bracket: 0.80 kg  
Add for digital display: 0.13 kg  
Add for mounting bracket: 0.60 kg

## Characteristics of Control Option

### PID

Proportional Gain: 0 to 100  
Integral Time: 0.01 to 999 min/rep  
Derivative Time: 0 to 999 s  
Direct/Reverse Action  
Lower and Upper output limits  
Output rate-of-change limit: 0.02 to 600 %/s  
Power-on safety output  
Antireset wind-up  
Bumpless Auto/Manual transfer  
Setpoint Generator up to 16 points, up to 19999 minutes

### Alarm

Dual, trip levels adjustable over entire range.  
High or Low action.  
Acknowledge, messaging

SENSOR	2, 3 or 4 wires					DIFFERENTIAL			
	TYPE	RANGE °C	RANGE °F	MINIMUM SPAN °C	°C DIGITAL ACCURACY*	RANGE °C	RANGE °F	MINIMUM SPAN °C	°C DIGITAL ACCURACY*
RTD	Cu 10 GE	-20 to 250	-4 to 482	50	± 1.0	-270 to 270	-486 to 486	50	± 2.0
	Ni120 DIN	-50 to 270	-58 to 518	5	± 0.1	-320 to 320	-576 to 576	5	± 0.5
	Pt50 IEC	-200 to 850	-328 to 1562	10	± 0.25	-1050 to 1050	-1890 to 1890	10	± 1.0
	Pt100 IEC	-200 to 850	-328 to 1562	10	± 0.2	-1050 to 1050	-1890 to 1890	10	± 1.0
	Pt500 IEC	-200 to 450	-328 to 842	10	± 0.2	NA	NA	NA	NA
	Pt50 JIS	-200 to 600	-328 to 1112	10	± 0.25	-800 to 800	-1440 to 1440	10	± 1.0
	Pt100 JIS	-200 to 600	-328 to 1112	10	± 0.25	-800 to 800	-1440 to 1440	10	± 1.5
THERMO-COUPLE	BNBS	100 to 1800	212 to 3272	50	± 0.5**	-1700 to 1700	-3060 to 3060	60	± 1.0**
	ENBS	-100 to 1000	-148 to 1832	20	± 0.2	-1100 to 1100	-1980 to 1980	20	± 1.0
	JNBS	-150 to 750	-238 to 1382	30	± 0.3	-900 to 900	-1620 to 1620	30	± 0.6
	KNBS	-200 to 1350	-328 to 2462	60	± 0.6	-1550 to 1550	-2790 to 2790	60	± 1.2
	NNBS	-100 to 1300	-148 to 2372	50	± 0.5	-1400 to 1400	-2520 to 2520	50	± 1.0
	RNBS	0 to 1750	32 to 3182	40	± 0.4	-1750 to 1750	-3150 to 3150	40	± 2.0
	SNBS	0 to 1750	32 to 3182	40	± 0.4	-1750 to 1750	-3150 to 3150	40	± 2.0
	TNBS	-200 to 400	-328 to 752	15	± 0.15	-600 to 600	-1080 to 1080	15	± 0.8
	LDIN	-200 to 900	-328 to 1652	35	± 0.35	-1100 to 1100	-1980 to 1980	35	± 0.7
UDIN	-200 to 600	-328 to 1112	50	± 0.5	-800 to 800	-1440 to 1440	50	± 2.5	

\* Accuracy of value read on display and accessed by communication using HT2. The 4-20 mA accuracy is the digital accuracy ±0.03%

\*\* Not applicable for the first 20% of the range (up to 440 °C).

NA: Not applicable.

SENSOR	RANGE mV	MINIMUM SPAN mV	DIGITAL* ACCURACY %
mV	-6 to 22	0.40	± 0.02% or ± 2 µV
	-10 to 100	2.00	± 0.02% or ± 10 µV
	-50 to 500	10.00	± 0.02% or ± 50 µV
mV DIF.	-28 to 28	0.40	± 0.1% or ± 10 µV
	-110 to 110	2.0	± 0.1% or ± 50 µV

SENSOR	RANGE Ohm	MINIMUM SPAN Ohm	DIGITAL* ACCURACY %
Ohm	0 to 100	1	± 0.02% or ± 0.01 Ohm
	0 to 400	4	± 0.02% or ± 0.04 Ohm
	0 to 2000	20	± 0.02% or ± 0.201 Ohm
Ohm DIF.	-100 to 100	1	± 0.08% or ± 0.04 Ohm
	-400 to 400	4	± 0.1% or ± 0.2 Ohm

Dimensions are mm (in)

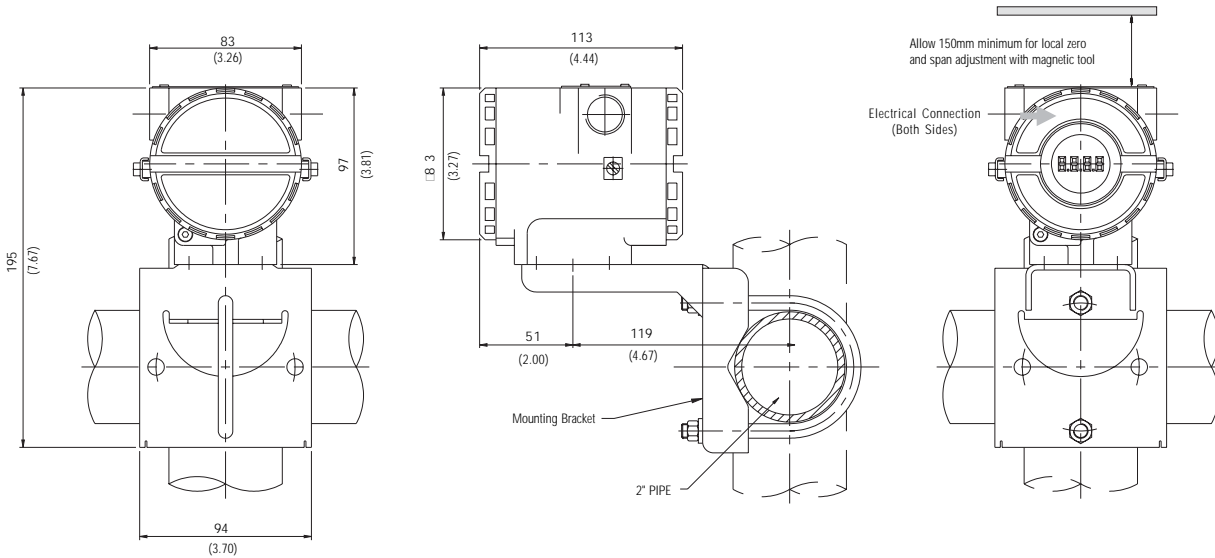

## ORDERING CODE

MODEL	SMART TEMPERATURE TRANSMITTERS
TT301	
CODE	Local Indicator
0	Without Indicator
1	With Digital Indicator
CODE	Mounting Bracket
0	Without Bracket
1	Carbon Steel Bracket
2	316 SS Bracket
7	Carbon Steel Bracket with 316 SST Fasteners
CODE	Zero and Span Adjustment
1	With Local Adjustment
CODE	Electrical Connections
0	½ - 14 NPT
A	M20 X 1.5
B	Pg 13,5 DIN
Z	Others - Specify
CODE	Optional Items *
H1	316 SST Housing
ZZ	Special Options - Specify

TT301 0 2 1 B ← TYPICAL MODEL NUMBER

\* Leave it blank for no optional items.



INGENIEROS ASOCIADOS DE CONTROL S.L.

Telf.: 913831390  
comercial@iac-sl.es