

General Specifications

Model EJA210A and EJA220A Flange Mounted Differential Pressure Transmitter

DP_{harp}



INGENIEROS ASOCIADOS DE CONTROL S.L.
Tel: 913831390
comercial@iac-si.es

GS 01C21C01-00E

The high performance flange mounted differential pressure transmitter models EJA210A and 220A can be used to measure levels of densities of solidifying or precipitating liquids. Both output a 4 to 20 mA DC signal corresponding to the measured differential pressure. Models EJA210A and 220A also feature remote setup and monitoring through communications with the BRAIN™ terminal and CENTUM CS™ or μXL™ or HART® 275 host.

STANDARD SPECIFICATIONS

Refer to GS 01C22T02-00E for Fieldbus communication type marked with “◇.”

PERFORMANCE SPECIFICATIONS

Zero-based calibrated span, linear output, wetted parts material code ‘S’ for 3-inch flange flush type and 4-inch flange extended type.

Reference Accuracy of Calibrated Span

(including the effects of zero-based linearity, hysteresis, and repeatability)

±0.075 % of Span

For spans below X,

$\pm [0.025 + 0.05 \frac{X}{\text{Span}}] \%$ of Span

where X equals:

Capsule	X kPa {inH ₂ O}
M	10 {40}
H	100 {400}

Ambient Temperature Effects

Total Effects per 28 °C (50 °F) Change

Capsule	Effect
M	±[0.224 % Span + 0.056 % URL]
H	±[0.14 % Span + 0.028 % URL]

Static Pressure Effects

Total Effects per Change

±[0.028 % Span+0.007 % URL] per 0.69 MPa {100 psi}

Effect on Zero (can be corrected at line pressure)

±0.007 % of URL per 0.69 MPa {100 psi}

Stability

±0.1 % of URL per 12 months

Power Supply Effects “◇”

±0.005 % per Volt (from 21.6 to 32 V DC, 350 Ω)

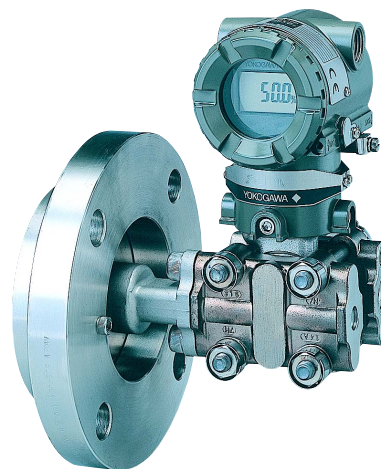

FUNCTIONAL SPECIFICATIONS

Span & Range Limits

Measurement Span and Range		kPa	inH ₂ O (/D1)	mbar (/D3)	mmH ₂ O (/D4)
M	Span	1 to 100	4 to 400	10 to 1000	100 to 10000
	Range	-100 to 100	-400 to 400	-1000 to 1000	-10000 to 10000
H	Span	5 to 500	20 to 2000	50 to 5000	0.05 to 5 kgf/cm ²
	Range	-500 to 500	-2000 to 2000	-5000 to 5000	-5 to 5 kgf/cm ²

T01E.EPS

URL is defined as the Upper Range Limit from the table above.

Zero Adjustment Limits

Zero can be fully elevated or suppressed, within the Lower and Upper Range Limits of the capsule.

External Zero Adjustment “◇”

External zero is continuously adjustable with 0.01 % incremental resolution of span. Span may be adjusted locally using the digital indicator with range switch.

Output “◇”

Two wire 4 to 20 mA DC output with digital communications. BRAIN or HART FSK protocol are superimposed on the 4 to 20 mA signal.

Failure Alarm

Output status at CPU failure and hardware error;
Up-scale: 110%, 21.6 mA DC or more(standard)
Down-scale: -5%, 3.2 mA DC or less
Note: Applicable for Output signal code D and E

Damping Time Constant (1st order)

The sum of the amplifier and capsule damping time constant must be used for the overall time constant. Amp damping time constant is adjustable from 0.2 to 64 seconds.

Model	EJA210A		EJA220A	
Capsule (Silicone Oil)	M	H	M	H
Time Constant (sec.)	0.4	0.4	0.4	0.4

Ambient Temperature Limits

(approval codes may affect limits)

- 40 to 85 °C (-40 to 185 °F)
- 30 to 80 °C (-22 to 176 °F) with LCD Display

Process Temperature Limits

(approval codes may affect limits)

- 40 to 120 °C (-40 to 248 °F)

Ambient Humidity Limits

- 5 to 100 % RH @ 40 °C (104 °F)

Working Pressure Limits (Silicone Oil)

2.7 kPa abs(0.38 psia) to flange rating (see graph below)

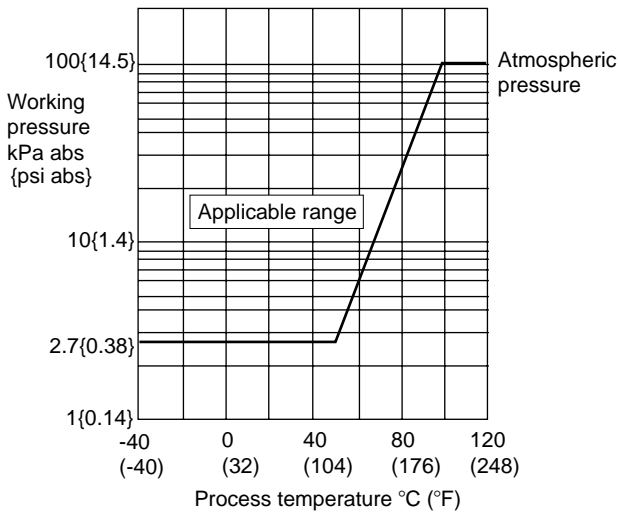

Figure 1. Working Pressure and Process Temperature

EMC Conformity Standards CE , N200

EN61326, AS/NZS 2064

Supply & Load Requirements

(Safety approvals may affect electrical requirements)
With 24 V DC supply, up to a 570 Ω load can be used. See graph below.

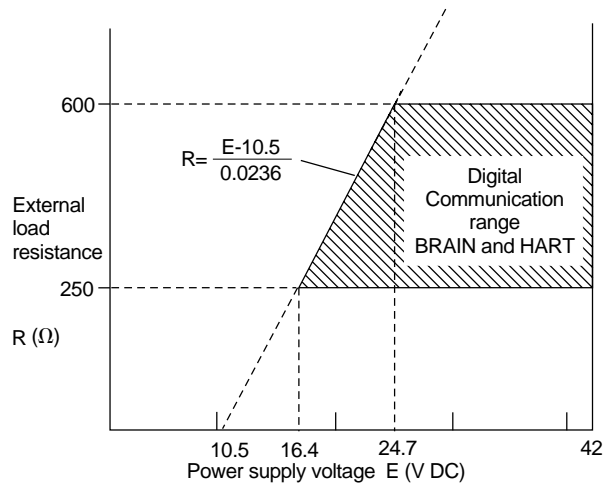

Figure 2. Relationship Between Power Supply Voltage and External Load Resistance

Supply Voltage “◇”

- 10.5 to 42 V DC for operation(10.5 to 30 V DC for Intrinsically safe type)
- 16.4 to 42 V DC for digital communications(16.4 to 30 V DC for Intrinsically safe type)

Load (Output signal code D and E)

- 0 to 1335 Ω for operation
- 250 to 600 Ω for digital communication

Communication Requirements “◇”

BRAIN

Communication Distance

Up to 2 km (1.25 miles) when using CEV polyethylene-insulated PVC-sheathed cables. Communication distance varies depending on type of cable used.

Load Capacitance

0.22 μF or less (see note)

Load Inductance

3.3 mH or less (see note)

Input Impedance of communicating device

10 kΩ or more at 2.4 kHz.

Note : For general-use and Flameproof type.
For Intrinsically safe type, please refer to 'OPTIONAL SPECIFICATIONS.'

HART

Communication Distance

Up to 1.5 km (1 mile) when using multiple twisted pair cables. Communication distance varies depending on type of cable used.

Use the following formula to determine cable length for specific applications:

$$L = \frac{65 \times 10^6}{(R \times C)} - \frac{(C_f + 10,000)}{C}$$

Where:

- L = length in meters or feet
- R = resistance in Ω (including barrier resistance)
- C = cable capacitance in pF/m or pF/ft
- C_f = maximum shunt capacitance of receiving devices in pF/m or pF/ft

□ **PHYSICAL SPECIFICATIONS**

Wetted Parts Materials

High side:

See wetted parts materials of the model code

Low side:

Diaphragm

Hastelloy C-276

Cover flange

SCS14A

Process connector

SCS14A

Capsule Gasket

Teflon-coated SUS316L

Vent and Drain Plug

SUS316

Process Connector Gasket

PTFE Teflon

Non-wetted Parts Materials

Bolting

SCM435 CS or SUS630

Housing

Low copper cast-aluminum alloy with polyurethane paint (Munsell 0.6GY3.1/2.0)

Degrees of Protection

IP67, NEMA4X, JIS C0920 immersion proof

Cover O-rings

Buna-N

Name plate and tag

SUS304

Fill Fluid

Silicone, Fluorinated oil(option)

Weight

10.7 kg(23.6 lb) (Model EJA210A with 3" ANSI 150 flange; without integral indicator and process connector.)

16.1 kg(35.5 lb) (Model EJA220A with 4" ANSI 150 flange, X₂= 100; without integral indicator and process connector.)

Connections

Refer to the model code to specify the process and electrical connection type. The high pressure side will be a flange connected, low pressure side is threaded.

< Settings When Shipped > “◇”

Tag Number	As specified in order *1
Output Mode	'Linear' unless otherwise specified in order
Display Mode	'Linear' unless otherwise specified in order
Operation Mode	'Normal' unless otherwise specified in order
Damping Time Constant *2	'2 sec.'
Calibration Range Lower Range Value	As specified in order
Calibration Range Higher Range Value	As specified in order
Calibration Range Units	Selected from mmH ₂ O, mmAq, mmWG, mmHg, Pa, hPa, kPa, MPa, mbar, bar, gf/cm ² , kgf/cm ² , inH ₂ O, inHg, ftH ₂ O, or psi. (Only one unit can be specified)

T07E.EPS

*1: Up to 16 alphanumeric characters (including - and .) will be entered in the amplifier memory.

*2: If using square root output, set damping time constant to 2 sec. or more.

< Related Instruments > “◇”

Power Distributor: Refer to GS 01B04T01-02E or GS 01B04T02-00E

BRAIN TERMINAL: Refer to GS 01C00A11-00E

< Reference >

1. Teflon; Trademark of E.I. DuPont de Nemours & Co.
2. Hastelloy; Trademark of Haynes International Inc.
3. HART; Trademark of the HART Communication Foundation.
4. FOUNDATION; Trademark of Fieldbus Foundation.

Material Cross Reference Table

SUS316L	AISI 316L
SUS316	AISI 316
SUS304	AISI 304
S25C	AISI 1025
SCM435	AISI 4137
SUS630	ASTM630
SCS14A	ASTM CF-8M

T010E.EPS

< Specification Conformance >

The model EJA210A/220A maintains a specification conformance to at least 3 σ .

MODEL AND SUFFIX CODES

Model EJA210A [Process Flange size: 3-inch (80 mm)]

Model	Suffix Codes	Description
EJA210A	Flange-mounted differential pressure transmitter (Flush diaphragm type)
Output Signal	-D -E -F	4 to 20 mA DC with digital communication (BRAIN protocol) 4 to 20 mA DC with digital communication (HART protocol, refer to GS 01C22T01-00E) Digital communication (FOUNDATION Fieldbus protocol, refer to GS 01C22T02-00E)
Measurement span (capsule)	M H	1 to 100 kPa {100 to 10000 mmH ₂ O} 5 to 500 kPa {0.05 to 5 kgf/cm ² }
High pressure side (Process flange side) wetted parts material*1	S H T	[Diaphragm] [Others] SUS316L SUS316 Hastelloy C-276 Hastelloy C-276 Tantalum Tantalum
Process flange rating	J1 J2 A1 A2 P1 P2 D2 D4	JIS10K JIS20K ANSI Class 150 ANSI Class 300 JPI Class150 JPI Class 300 DIN PN10/16 DIN PN25/40
Process flange size / material ☆	D E F	3-inch (80 mm) / S25C 3-inch (80 mm) / SUS304 3-inch (80 mm) / SUS316
Low pressure side process connection ☆	0 1 2 3 4 5	without process connector (Rc1/4 female on the cover flange) with Rc1/4 female process connector with Rc1/2 female process connector with 1/4NPT female process connector with 1/2NPT female process connector without process connector (1/4 NPT female on the cover flange)
Bolts and nuts material ☆	A B C	SCM435 SUS630 SUH660
Installation	-9	Horizontal impulse piping type, left side high pressure
Electrical connection ☆	0 2 3 4 5 7 8 9	G1/2 female, one electrical connection 1/2 NPT female, two electrical connections without blind plug Pg 13.5 female, two electrical connections without blind plug M20 female, two electrical connections without blind plug G1/2 female, two electrical connections and a blind plug 1/2 NPT female, two electrical connections and a blind plug Pg 13.5 female, two electrical connections and a blind plug M20 female, two electrical connections and a blind plug
Integral indicator ☆	D E N	Digital indicator Digital indicator with the range setting switch (None)
Optional codes	N	Always N
		<input type="checkbox"/> Optional specification

T04E.EPS

The '☆' marks indicate the most typical selection for each specification. Example: EJA210A-DMSA1D5A-92NN□

*1: Low pressure side wetted parts material: Cover flange; SCS14A, Process connector; SCS14A, Capsule; SUS316L (Diaphragm; Hastelloy C-276), Vent plug; SUS316

● Model EJA210A [Process Flange size: 2-inch (50 mm)]

Model	Suffix Codes	Description
EJA210A	Flange-mounted differential pressure transmitter (Flush diaphragm type)
Output Signal	-D -E -F	4 to 20 mA DC with digital communication (BRAIN protocol) 4 to 20 mA DC with digital communication (HART protocol, refer to GS 01C22T01-00E) Digital communication (FOUNDATION Fieldbus protocol, refer to GS 01C22T02-00E)
Measurement span (capsule)	M H	1 to 100 kPa {100 to 10000 mmH ₂ O} 5 to 500 kPa {0.05 to 5 kgf/cm ² }
High pressure side (Process flange side) wetted parts material*1	W	[Diaphragm] [Others] Hastelloy C-276 SUS316
Process flange rating	J1 J2 A1 A2 P1 P2 D2 D4	JIS10K JIS20K ANSI Class 150 ANSI Class 300 JPI Class150 JPI Class 300 DIN PN10/16 DIN PN25/40
Process flange size / material ☆	A B C	2-inch (50 mm) / S25C 2-inch (50 mm) / SUS304 2-inch (50 mm) / SUS316
Low pressure side process connection ☆	0 1 2 3 4 5	without process connector (Rc1/4 female on the cover flange) with Rc1/4 female process connector with Rc1/2 female process connector with 1/4NPT female process connector with 1/2NPT female process connector without process connector (1/4 NPT female on the cover flange)
Bolts and nuts material ☆	A B C	SCM435 SUS630 SUH660
Installation	-9	Horizontal impulse piping type, left side high pressure
Electrical connection ☆	0 2 3 4 5 7 8 9	G1/2 female, one electrical connection 1/2 NPT female, two electrical connections without blind plug Pg 13.5 female, two electrical connections without blind plug M20 female, two electrical connections without blind plug G1/2 female, two electrical connections and a blind plug 1/2 NPT female, two electrical connections and a blind plug Pg 13.5 female, two electrical connections and a blind plug M20 female, two electrical connections and a blind plug
Integral indicator ☆	D E N	Digital indicator Digital indicator with the range setting switch (None)
Optional codes	N	Always N
		<input type="checkbox"/> Optional specification

T005E.EPS

The '☆' marks indicate the most typical selection for each specification. Example: EJA210A-DMWA1A5A-92NN/□

*1: Low pressure side wetted parts material: Cover flange; SCS14A, Process connector; SCS14A, Capsule; SUS316L (Diaphragm; Hastelloy C-276), Vent plug; SUS316

● Model EJA220A

Model	Suffix Codes	Description
EJA220A	Flange-mounted differential pressure transmitter (Extended diaphragm type)
Output Signal	-D -E -F	4 to 20 mA DC with digital communication (BRAIN protocol) 4 to 20 mA DC with digital communication (HART protocol, refer to GS 01C22T01-00E) Digital communication (FOUNDATION Fieldbus protocol, refer to GS 01C22T02-00E)
Measurement span (capsule)	M H	1 to 100 kPa {100 to 10000 mmH ₂ O} 5 to 500 kPa {0.05 to 5 kgf/cm ² }
High pressure side (Process flange side) wetted parts material ^{*1}	S ^{*2} W ^{*3}	[Diaphragm] [Pipe] [Others] SUS316L SUS316 SUS316 Hastelloy C-276 SUS316 SUS316
Process flange rating	J1 J2 A1 A2 P1 P2 D2 D4	JIS10K JIS20K ANSI Class 150 ANSI Class 300 JPI Class 150 JPI Class 300 DIN PN10/16 DIN PN25/40
Diaphragm extension length (X ₂) ☆	2 4 6	X ₂ =50 mm X ₂ =100 mm X ₂ =150 mm
Process flange size/material ☆	G H J D E F	4-inch (100 mm) / S25C 4-inch (100 mm) / SUS304 4-inch (100 mm) / SUS316 3-inch (80 mm) / S25C 3-inch (80 mm) / SUS304 3-inch (80 mm) / SUS316
Low pressure side process connection ☆	0 1 2 3 4 5	without process connector (Rc1/4 female on the cover flanges) with Rc1/4 female process connector with Rc1/2 female process connector with 1/4 NPT female process connector with 1/2 NPT female process connector without process connector (1/4 NPT female on the cover flanges)
Bolts and nuts material ☆	A B C	SCM435 SUS630 SUH660
Installation	-g	Horizontal impulse piping type, left side high pressure
Electrical connection ☆	0 2 3 4 5 7 8 9	G1/2 female, one electrical connection 1/2 NPT female, two electrical connections without blind plug Pg 13.5 female, two electrical connections without blind plug M20 female, two electrical connections without blind plug G1/2 female, two electrical connections and a blind plug 1/2 NPT female, two electrical connections and a blind plug Pg 13.5 female, two electrical connections and a blind plug M20 female, two electrical connections and a blind plug
Integral indicator ☆	D E N	Digital indicator Digital indicator with the range setting switch (None)
Optional codes	N	Always N
		<input type="checkbox"/> Optional specification

T06E.EPS

The '☆' marks indicate the most typical selection for each specification. Example: EJA220A-DMSA12G5A-92NN/□

- *1: Low pressure side wetted parts material: Cover flange; SCS14A, Process connector; SCS14A, Capsule; SUS316L (Diaphragm, Hastelloy C-276), Vent plug; SUS316
- *2: Applicable for 4-inch (100 mm) flange size (Process flange size/material G and H).
- *3: Applicable for 3-inch (80 mm) flange size (Process flange size/material D and E).

OPTIONAL SPECIFICATIONS (For Explosion Protected type “◇”)

For FOUNDATION Fieldbus explosion protected type, see GS 01C22T02-00E.

Item	Description	Code
Factory Mutual (FM)	FM Explosionproof Approval *3 Explosionproof for Class I, Division 1, Groups B, C and D Dust-ignitionproof for Class II/III, Division 1, Groups E, F and G Hazardous (classified) locations, indoors and outdoors (NEMA 4X) Temperature class : T6 Amb. Temp. : -40 to 60 °C (-40 to 140 °F) Electrical connection : 1/2 NPT female *1	FF1
	FM Intrinsically safe Approval *3 Intrinsically Safe for Class I, Division 1, Groups A, B, C & D, Class II, Division 1, Groups E, F & G and Class III, Division 1 Hazardous Locations. Nonincendive for Class I, Division 2, Groups A, B, C & D, Class II, Division. 2, Groups E, F & G, and Class III, Division 1 Hazardous Locations. Enclosure : "NEMA 4X", Temp. Class : T4, Amb. Temp. : -40 to 60 °C (-40 to 140 °F) Intrinsically Safe Apparatus Parameters [Groups A, B, C, D, E, F and G] Vmax=30 V, Imax=165 mA, Pmax=0.9 W, Ci=22.5 nF, Li=730 μH [Groups C, D, E, F and G] Vmax=30 V, Imax=225 mA, Pmax=0.9 W, Ci=22.5 nF, Li=730 μH Electrical connection : 1/2 NPT female *1	FS1
	Combined FF1 and FS1 *3 Electrical connection : 1/2 NPT female *1	FU1
CENELEC ATEX	CENELEC ATEX (KEMA) Flameproof Approval *3 [PENDING] EExd IIC T4, T5, T6 Amb. Temp. : T5 ; -40 to 80 °C (-40 to 176 °F), T4 and T6 ; -40 to 75°C (-40 to 167°F) Max. process Temp. : T4 ; 120 °C (248 °F), T5 ; 100 °C (212 °F), T6 ; 85 °C (185 °F) Electrical connection : 1/2 NPT female and M20 female *2	
	CENELEC ATEX (KEMA) Intrinsically safe Approval *3 EEx ia IIC T4, Amb. Temp. : -40 to 60 °C (-40 to 140 °F) Ui=30 V, Ii=165 mA, Pi=0.9 W, Ci=22.5 nF, Li=730 μH Electrical connection : 1/2 NPT female and M20 female *2	KS2
	CENELEC ATEX Type of protection "n" *3 Ex nL IIC T4, Amb. Temp. : -40 to 60 °C (-40 to 140 °F) U=30 V Electrical connection : 1/2 NPT female and M20 female *2	KN2
CENELEC (KEMA)	CENELEC (KEMA) Flameproof, Intrinsically safe, and Type n Approval Ex nA IIC T4, Amb. Temp. : -40 to 60 °C (-40 to 140 °F) U=30 V, I=165 mA Electrical connection : 1/2 NPT female, Pg 13.5 female and M20 female *4	KU1
Canadian Standards Association (CSA)	CSA Explosionproof Approval *3 Explosionproof for Class I, Division 1, Groups B, C and D Dustignitionproof for Class II/III, Division 1, Groups E, F and G Division2 'SEALS NOT REQUIRED', Temp. Class : T4, T5, T6 Encl Type 4x Max. Process Temp. : T4 ; 120 °C (248 °F), T5 ; 100 °C (212 °F), T6 ; 85 °C (185 °F) Amb. Temp. : -40 to 80 °C (-40 to 176 °F) Electrical connection : 1/2 NPT female *1	CF1
	CSA Intrinsically safe Approval *3 Class I, Groups A, B, C and D Class II and III, Groups E, F and G Encl Type 4x, Temp. Class : T4, Amb. Temp. : -40 to 60 °C (-40 to 140 °F) Vmax=30 V, Imax=165 mA, Pmax=0.9 W, Ci=22.5 nF, Li=730 μH Electrical connection : 1/2 NPT female *1	CS1
	Combined CF1 and CS1 *3 Electrical connection : 1/2 NPT female *1	CU1
Standards Association of Australia (SAA)	SAA Flameproof, Intrinsically safe and Non-sparking Approval *3 Ex d IIC T4/T5/T6, IP67 class I, Zone 1, Amb. Temp. : -40 to 80 °C (-40 to 176 °F) Max. Process Temp. : T4 ; 120 °C (248 °F), T5 ; 100 °C (212 °F), T6 ; 85 °C (185 °F) Ex ia IIC T4, IP67 class I, Zone 0 Ex n IIC T4, IP67 class I, Zone 2 Ui=30 V DC, Ii=165 mA DC, Wi=0.9 W, Amb. Temp. : -40 to 60 °C (-40 to 140 °F) Electrical connection : 1/2 NPT female, Pg 13.5 female and M20 female *4	SU1

T007E.EPS

- *1: Applicable for Electrical connection code 2 and 7.
- *2: Applicable for Electrical connection code 2, 4, 7 and 9.
- *3: Applicable for Output signal code D and E.
For intrinsically safe approval, use the safety barrier certified by the testing laboratories (BARD-400 is not applicable).
- *4: Applicable for Electrical connection code 2, 3, 4, 7, 8 and 9.

OPTIONAL SPECIFICATIONS

Item		Description	Code
Painting	Color change	Amplifier cover only	P□
	Coating change	Epoxy resin-baked coating	X1
Lightning protector		Transmitter power supply voltage: 10.5 to 32 V DC (10.5 to 30 V DC for intrinsically safe type, 9 to 32 V DC for Fieldbus communication type.) Allowable current: Max. 6000 A (1×40 μs), Repeating 1000 A (1×40 μs) 100 times	A
Oil-prohibited use		Degrease cleansing treatment	K1
		Degrease cleansing treatment and with fluorinated oil filled capsule. Operating temperature -20 to 80°C	K2
Oil-prohibited use with dehydrating treatment		Degrease cleansing treatment and dehydrating treatment	K5
		Degrease cleansing treatment and dehydrating treatment with fluorinated oil filled capsule. Operating temperature -20 to 80°C	K6
No serration*1		No serration work on the flange gasket surface (for ANSI flange only)	Q
Teflon film *2		Diaphragm protection from sticky process fluid by FEP Teflon film attached with fluorinated oil. Operation range: 20 to 120°C, 0 to 2 MPa (Not applicable for vacuum service).	T
Fast response *11		Update time: 0.125 sec or less Amplifier damping time constant: 0.1 to 64 sec in 9 increments Response time (with min. damping time constant): max. 0.5 sec (excluding level unit)	F1
Failure alarm down-scale *3		Output status at CPU failure and hardware error is -5%, 3.2 mA or less.	C1
NAMUR NE43 compliant *3 *12		Output signal limits: 3.8 mA to 20.5 mA	Failure alarm down-scale: output status at CPU failure and hardware error is -5%, 3.2 mA or less.
			Failure alarm up-scale: output status at CPU failure and hardware error is 110%, 21.6 mA or more.
Stainless steel amplifier housing *4		Amplifier housing material: SCS14A stainless steel (equivalent to SUS316 cast stainless steel or ASTM CF-8M)	E1
Gold-plate *5		Inside of isolating diaphragms (fill fluid side) are gold plated, effective for hydrogen permeation. (process flange side)	A1
Stainless steel tag plate		SUS304 stainless steel tag plate wired onto transmitter	N4
Mill Certificate		High pressure side: Process flange, Block *6 Low pressure side: Cover flange	For model EJA210A
		High pressure side: Process flange, Block *7 Low pressure side: Cover flange, Process connector	M13
		High pressure side: Process flange, Block, Pipe, Base *6 Low pressure side: Cover flange	For model EJA220A
		High pressure side: Process flange, Block, Pipe, Base *7 Low pressure side: Cover flange, Process connector	M14
Pressure test/Leak test Certificate		(Flange rating) (Test Pressure)	
		JIS 10K 2 MPa {20 kgf/cm ² }	Nitrogen (N ₂) Gas *10 Retention time: 10 minutes
		JIS 20K 5 MPa {50 kgf/cm ² }	
		ANSI/JPI Class 150 3 MPa {29.8 kgf/cm ² }	
		ANSI/JPI Class 300 7.7 MPa {77 kgf/cm ² } *8	
		ANSI/JPI Class 300 7 MPa {70 kgf/cm ² } *9	
	T31		
	T32		
	T36		
	T37		
	T38		

T08E.EPS

- *1: This item cannot be applied to model EJA210A Wetted parts material code H and T, whose gasket contact surface are not serrated as standard specifications.
- *2: Teflon film can only be specified for model EJA210A.
- *3: Applicable for Output signal code D and E. The hardware error indicates faulty amplifier or capsule. When combining with Optional code F1, output status for down-scale is -2.5%, 3.6 mA DC or less.
- *4: Applicable for Electrical connection code 2, 3, 4, and 7. Not applicable for Optional code P□ and X1.
- *5: Applicable for Wetted parts material code S and W. Consult Yokogawa in case gold-plated diaphragm is required for low pressure side.
- *6: Applicable for Low Pressure Side Process connection code 0 and 5.
- *7: Applicable for Low Pressure Side Process connection code 1, 2, 3, and 4.
- *8: Applicable for model EJA210A.
- *9: Applicable for model EJA220A.
- *10: Pure nitrogen gas is used for oil-prohibited use (Optional code K1, K2, K5, and K6).
- *11: Applicable for Output signal code D and E. Consult Yokogawa when combining with Optional code for explosion protected type.
- *12: Not applicable for Optional code C1.

Item	Description	Code	
Calibration units*1	P calibration (psi unit)	(See Table for Span and Range Limits.) D1	
	bar calibration (bar unit)		D3
	M calibration (kgf/cm ² unit)		D4
Sealing treatment to SUS630 nuts	Sealant(liquid silicone rubber) is coated on JIS SUS630 cover flange mounting nuts against stress corrosion cracking.	Y	

T10E.EPS

*1: The unit of MWP (Max. working pressure) on name plate of a housing is the same unit as specified by Optional code D1, D3, and D4.

DIMENSIONS

● Model EJA210A

Unit: mm (approx.inch)

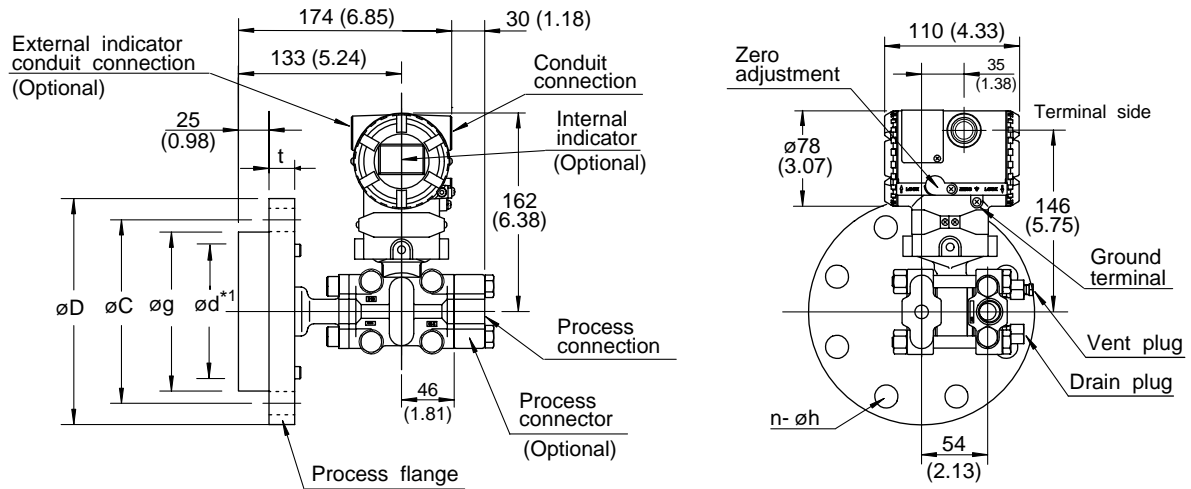

*1 Indicates inside diameter of gasket contact surface.

Flange size: 3-inch (80 mm)

Flange Nominal Diameter and Rating	øD	øC	øg	ød	t	Bolt Holes	
						No.(N)	Dia.(øh)
JIS 10K	185(7.28)	150(5.91)	130(5.12)	90(3.54)	18(0.71)	8	19(0.75)
JIS 20K	200(7.87)	160(6.30)	130(5.12)	90(3.54)	22(0.87)	8	23(0.91)
ANSI Class150	190.5(7.50)	152.4(6.00)	130(5.12)	90(3.54)	23.9(0.94)	4	19.1(0.75)
ANSI Class300	209.6(8.25)	168.1(6.62)	130(5.12)	90(3.54)	28.5(1.12)	8	22.4(0.88)
JPI Class150	190(7.48)	152.4(6.00)	130(5.12)	90(3.54)	24(0.44)	4	19(0.75)
JPI Class300	210(8.27)	168.1(6.62)	130(5.12)	90(3.54)	28.5(1.12)	8	22(0.87)
DIN PN 10/16	200(7.87)	160(6.30)	130(5.12)	90(3.54)	20(0.79)	8	18(0.71)
DIN PN 25/40	200(7.87)	160(6.30)	130(5.12)	90(3.54)	24(0.44)	8	18(0.71)

Flange size: 2-inch (50 mm)

Flange Nominal Diameter and Rating	øD	øC	øg	ød	t	Bolt Holes	
						No.(N)	Dia.(øh)
JIS 10K	155(6.10)	120(4.72)	100(3.94)	61(2.40)	16(0.63)	4	19(0.75)
JIS 20K	155(6.10)	120(4.72)	100(3.94)	61(2.40)	18(0.71)	8	19(0.75)
ANSI Class150	152.4(6.00)	120.7(4.75)	100(3.94)	61(2.40)	19.1(0.75)	4	19.1(0.75)
ANSI Class300	165.1(6.50)	127(5.00)	100(3.94)	61(2.40)	22.4(0.88)	8	19.1(0.75)
JPI Class150	152(5.98)	120.6(4.75)	100(3.94)	61(2.40)	19.5(0.71)	4	19(0.75)
JPI Class300	165.1(6.50)	127(5.00)	100(3.94)	61(2.40)	22.5(0.89)	8	19(0.75)
DIN PN 10/16	165(6.50)	125(4.92)	100(3.94)	61(2.40)	18(0.71)	4	18(0.71)
DIN PN 25/40	165(6.50)	125(4.92)	100(3.94)	61(2.40)	20(0.79)	4	18(0.71)

F03E.EPS

● Model EJA220A

Unit: mm (approx.inch)

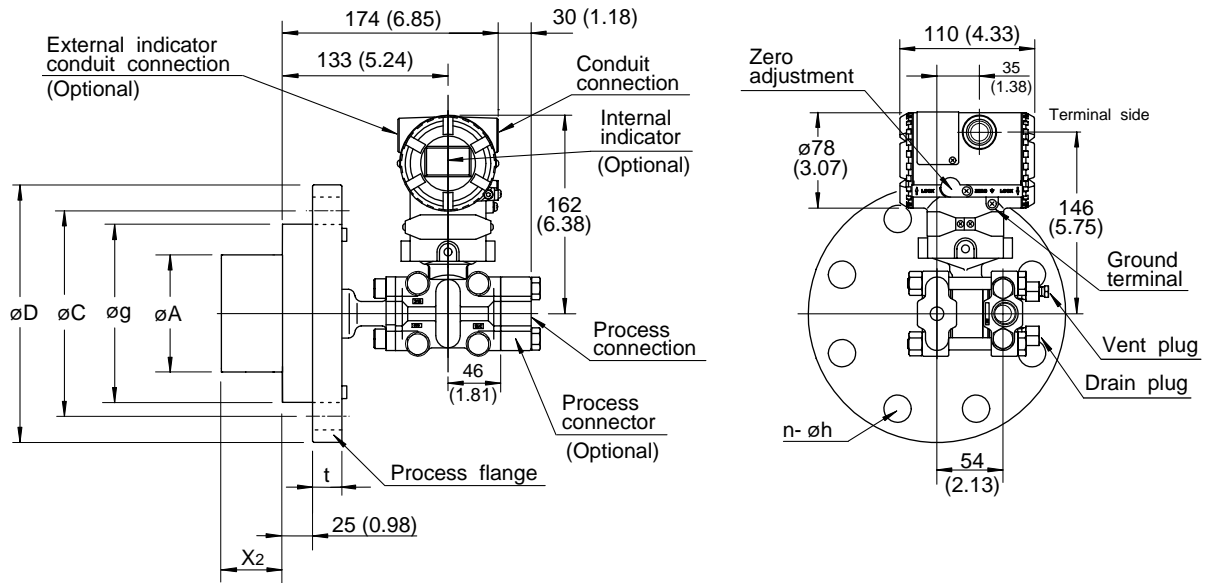

Flange size: 4-inch (100 mm)

Flange Nominal Diameter and Rating	øD	øC	øg	øA	t	Bolt Holes	
						No. (N)	Dia.(øh)
JIS 10K	210(8.27)	175(6.89)	155(6.10)	96±0.5(3.78)	18(0.71)	8	19(0.75)
JIS 20K	225(8.86)	185(7.28)	155(6.10)	96±0.5(3.78)	24(0.94)	8	23(0.91)
ANSI Class150	228.6(9.00)	190.5(7.50)	155(6.10)	96±0.5(3.78)	23.9(0.94)	8	19.1(0.75)
ANSI Class300	254(10.00)	200(7.87)	155(6.10)	96±0.5(3.78)	31.8(1.25)	8	22.4(0.88)
JPI Class150	229(9.02)	190.5(7.50)	155(6.10)	96±0.5(3.78)	24(0.94)	8	19(0.75)
JPI Class300	254(10.00)	200.2(7.88)	155(6.10)	96±0.5(3.78)	32(1.26)	8	22(0.87)
DIN PN 10/16	220(8.66)	180(7.09)	155(6.10)	96±0.5(3.78)	20(0.79)	8	18(0.71)
DIN PN 25/40	235(9.25)	190(7.50)	155(6.10)	96±0.5(3.78)	24(0.94)	8	22(0.87)

Flange size: 3-inch (80 mm)

Flange Nominal Diameter and Rating	øD	øC	øg	øA	t	Bolt Holes	
						No. (N)	Dia.(øh)
JIS 10K	185(7.28)	150(5.91)	130(5.12)	71±0.5(2.80)	18(0.71)	8	19(0.75)
JIS 20K	200(7.87)	160(6.30)	130(5.12)	71±0.5(2.80)	22(0.87)	8	23(0.91)
ANSI Class150	190.5(7.50)	152.4(6.00)	130(5.12)	71±0.5(2.80)	23.9(0.94)	4	19.1(0.75)
ANSI Class300	209.6(8.25)	168.1(6.62)	130(5.12)	71±0.5(2.80)	28.5(1.12)	8	22.4(0.88)
JPI Class150	190(7.48)	152.4(6.00)	130(5.12)	71±0.5(2.80)	24(0.94)	4	19(0.75)
JPI Class300	210(8.27)	168.1(6.62)	130(5.12)	71±0.5(2.80)	28.5(1.12)	8	22(0.87)
DIN PN 10/16	200(7.88)	160(6.30)	130(5.12)	71±0.5(2.80)	20(0.79)	8	18(0.71)
DIN PN 25/40	200(7.87)	160(6.30)	130(5.12)	71±0.5(2.80)	24(0.94)	8	18(0.71)

Diaphragm Extension Length Code	X ₂
2	1.97 inch (50 mm)
4	3.94 inch (100 mm)
6	5.91 inch (150 mm)

F04E.EPS

● Terminal Configuration

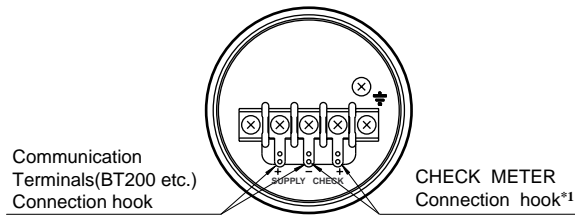

● Terminal Wiring

SUPPLY \pm	Power supply and output terminal
CHECK \pm	External indicator(ammeter) terminal*1
---	Ground terminal

*1: When using an external indicator or a check meter, the internal resistance must be 10 Ω or less. Not available for Fieldbus communication(Output signal code F).
F005E.EPS

■ SELECTION GUIDE

Application	Type	Model	Capsule	Measurement Span		Maximum Working Pressure	
				kPa	inH ₂ O	MPa	psi
Differential Pressure	Traditional-Mounting*1	EJA110A	L	0.5 to 10	2 to 40	16*4	500
			M	1 to 100	4 to 400	16	2000
			H	5 to 500	20 to 2000	16	2000
			V	0.14 to 14MPa	20 to 2000 psi	16	2000
Flow	Integral Orifice	EJA115	L	1 to 10	4 to 40	3.5	500
			M	2 to 100	8 to 400	14	2000
			H	20 to 210	80 to 830	14	2000
Differential Pressure & Liquid Level with Remote Seals	Extended Flush Combination	EJA118N EJA118W EJA118Y	M	2.5 to 100	10 to 400	Based on Flange Rating	
			H	25 to 500	100 to 2000		
Draft Range	Traditional-Mounting*1	EJA120A	E	0.1 to 1	0.4 to 4	50 kPa	7.25
Differential Pressure & Liquid Level	Traditional-Mounting*1	EJA130A	M	1 to 100	4 to 400	32	4500
			H	5 to 500	20 to 2000	32	4500
Liquid Level, Closed or Open Tank	Flush Extended	EJA210A EJA220A	M	1 to 100	4 to 400	Based on Flange Rating	
			H	5 to 500	20 to 2000		
Absolute (vacuum) Pressure	Traditional-Mounting*1	EJA310A	L	0.67 to 10*2	2.67 to 40*2	10 kPa*2	40 in H ₂ O*2
			M	1.3 to 130*2	0.38 to 38 inHg*2	130 kPa*2	18.65*2
			A	0.03 to 3 MPa*2	4.3 to 430 psi*2	3000 kPa*2	430*2
Gauge Pressure	Traditional-Mounting*1	EJA430A	A	0.03 to 3 MPa	4.3 to 430 psi	3	430
			B	0.14 to 14	20 to 2000 psi	14	2000
Gauge Pressure with Remote Seal	Extended	EJA438N	A	0.06 to 3 MPa	9 to 430 psi	Based on Flange Rating	
			B	0.46 to 7	66 to 1000 psi		
Gauge Pressure with Remote Seal	Flush	EJA438W	A	0.06 to 3 MPa	8 to 430 psi	Based on Flange Rating	
			B	0.46 to 7	66 to 2000 psi		
High Gauge	Traditional-Mounting*1	EJA440A	C	5 to 32 MPa	720 to 4500 psi	32	4500
			D	5 to 50 MPa	720 to 7200 psi	50	7200
Absolute & Gauge Pressure*3	Direct-Mounting	EJA510A EJA530A	A	10 to 200	1.45 to 29 psi	200 kPa	29
			B	0.1 to 2 MPa	14.5 to 290 psi	2	290
			C	0.5 to 10 MPa	72.5 to 1450 psi	10	1450
			D	5 to 50 MPa	720 to 7200 psi	50	7200

T009E.EPS

*1: Traditional-mounting is 1/4 - 18 NPTF process connections (1/2 - 14 NPTF with process adapters) on 2-1/8" centers.

*2: Measurement values in absolute.

*3: Measurement values in absolute for EJA510A.

*4: When combined with Wetted parts material code H, M, T, A, D, and B, the value is 3.5.

< Ordering Information > “◇”

Specify the following when ordering

1. Model, suffix codes, and optional codes

2. Calibration range and units:

1) Calibration range can be specified with range value specifications up to 5 digits (excluding any decimal point) for low or high range limits within the range of -32000 to 32000.

2) Specify only one unit from the table, 'Settings when shipped.'

3. Select linear or square root for output mode and display mode.

Note: If not specified, the instrument is shipped in normal operation mode.

4. Display scale and units (for transmitters equipped with integral indicator only)

Specify either 0 to 100 % or engineering unit scale and 'Range and Unit' for engineering units scale: Scale range can be specified with range limit specifications up to 5 digits (excluding any decimal point) for low or high range limits within the range of -19999 to 19999.

5. Tag Number (if required)

