

KARI

FLOAT SWITCH

NO LEAD
NO MERCURY

ALL IN ONE!

- alarm
- start
- stop
- alarm

Finnish quality product,
exported to over 30 countries
including U.S.A. and Japan.



Over 25 years experience in float switches

KARI-FINN OY



Gold medal at the
1977 "Brussels
International
Inventors Fair".



At the same time
presented with the
"City of Brussels"
medal



INGENIEROS ASOCIADOS DE CONTROL S.L.
Telf.: 913831390
comercial@iac-sl.es



KARI FLOAT SWITCH

The Kari Float Switch is a control device for filling and discharging pumps, motor and magnetic valves. It is also an alarm device at certain pre-determined surface levels. The Finnish Electrical Inspectorate, one of the most careful in Europe, has performed the tests according to the all-European CCA-agreement. They approved the Kari Float Switch for use in non-flammable liquids at 250 Volts. In dangerous environments (e.g. wells and pumping stations) we recommend 24 V voltage. In potentially explosive atmospheres (e.g. oil tanks) the Kari Float Switch can be used in connection with (Ex)i-isolator switch units. Due to its large float casing the Kari Float Switch has a buoyancy which guarantees smooth, trouble-free operation under all conditions.

STANDARD SWITCH TYPES ø 170 mm



	TYPE:	PRICE	OPERATION
DISCHARGE	1H		High level alarm or magnetic valve control
	2H		Discharging pump control or dry running prevention
	2Y		Discharging pump control or dry running prevention
	3H		Discharging pump control + high level alarm
	3HE		Discharging pump control + isolated high level alarm
	3Y		Discharging pump control + high level alarm
	3YE		Discharging pump control + isolated high level alarm
	4H		Discharging pump control + high and low level alarms
	4Y		Discharging pump control + high and low level alarms
CHARGE	1L		Low level alarm or magnetic valve control
	2L		Charging pump control
	2A		Charging pump control
	3L		Charging pump control + low level alarm
	3LE		Charging pump control + isolated low level alarm
	3A		Charging pump control + low level alarm
	3AE		Charging pump control + isolated low level alarm
	4L		Charging pump control + high and low level alarms
	4A		Charging pump control + high and low level alarms
	1C		Change over contact, alarm unit
	2HL		Alarm unit for expansion vessels, high and low alarm



WHEN ORDERING, THE FOLLOWING INFORMATION SHOULD BE GIVEN:

- type as per above or special requirements
- cable length if more than 5 meters
- height difference between upper and lower levels if smaller than 250 mm or greater than 1200 mm. (Min. 50 mm , max 2000 mm, but not available in the same float)

INSTALLATION

The Kari Float Switch is simply placed in the liquid so that the float follows the movement of the surface. The switching height differential is adjusted by moving the weight along the cable. The differential is on minimum, when the weight is nearest to the float. Complete instructions including a wiring diagram accompany every Kari Float Switch. These are also separately available on request.

If the viscosity of the liquid is high, we recommend an extra weight on the cable. Suitable auxiliary weights, which we supply to order, are as follows:

- Weight G  400 g, tightened onto the cable with a wedge, colour black
- Weight H  700 g, tightened onto the cable with a wedge, colour red
- Weight I  1000 g, tightened onto the cable with a wedge, colour grey

FLOAT SWITCHES CIRCUIT DIAGRAMS

**NO LEAD!
NO MERCURY!**



1H

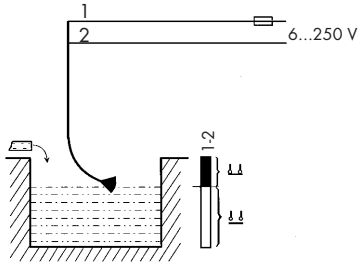

ALARM FROM HIGH LEVEL
ALARM VON DER OBERE HÖHE
ALARME HAUTE

1L

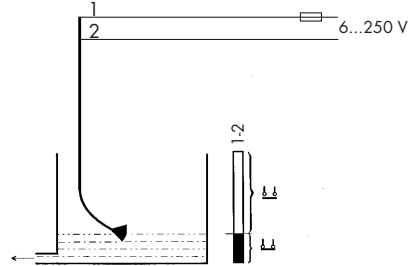

ALARM FROM LOW LEVEL
ALARM VON DER UNTERE HÖHE
ALARME BASSE

1C

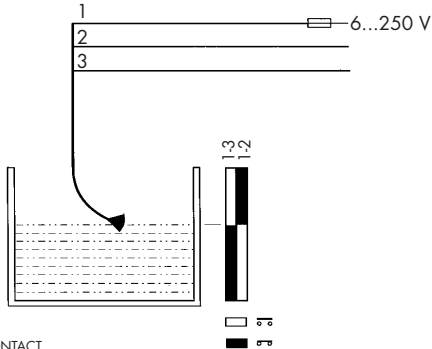

CHANGE OVER CONTACT

2HL

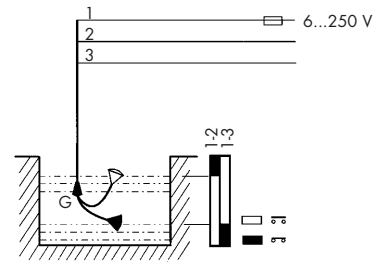

ALARM FROM HIGH AND LOW LEVEL
ALARM VON DER OBERE UND UNTERE HÖHE
ALARME NIVEAU HAUTE ET BASSE

2H

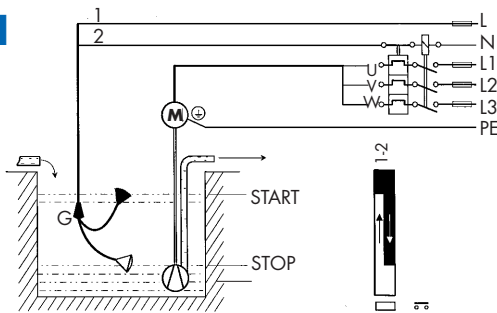

WIRING FOR EMPTYING OF SUBSOIL WATER PUMPS ETC.
SCHALTUNG FÜR ENTLEREEN VON GRUNDWASSERBRUNNEN USW.
COUPLAGE DE VIDANGE P.E.X. POUR PUITS ARTESIENS

2L

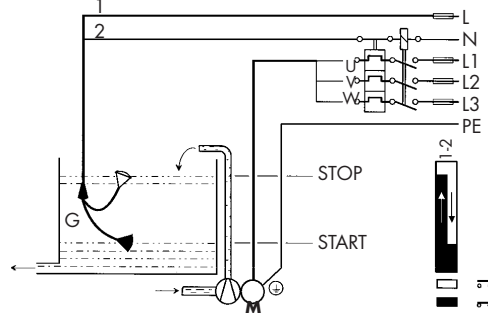

WIRING FOR FILLING OF STORAGE TANKS ETC.
SCHALTUNG FÜR FÜLLEN VON LAGERBEHÄLTER USW.
COUPLAGE DE REPISSAGE P.E.X. POUR RESERVOIRS DE STOCKAGE

2Y

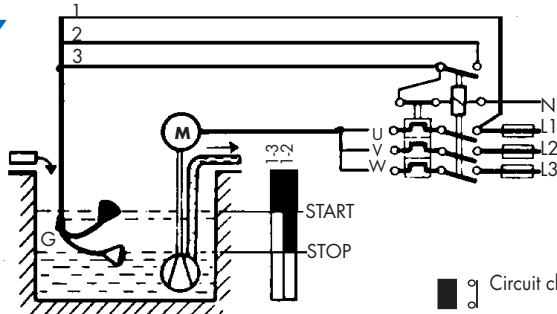

WIRING FOR EMPTYING OF SUBSOIL WATER PUMPS ETC.
SCHALTUNG FÜR ENTLEREEN VON GRUNDWASSERBRUNNEN USW.
COUPLAGE DE VIDANGE P.E.X. POUR PUITS ARTESIENS

2A

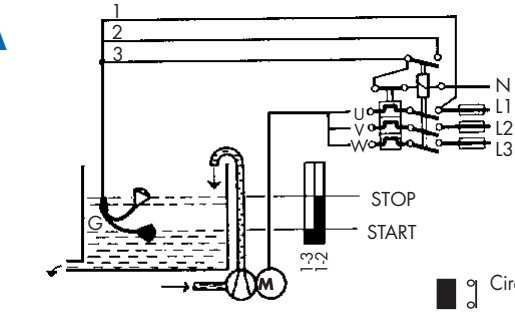

WIRING FOR FILLING OF STORAGE TANKS ETC.
SCHALTUNG FÜR FÜLLEN VON LAGERBEHÄLTER USW.
COUPLAGE DE REPISSAGE P.E.X. POUR RESERVOIRS DE STOCKAGE

3H

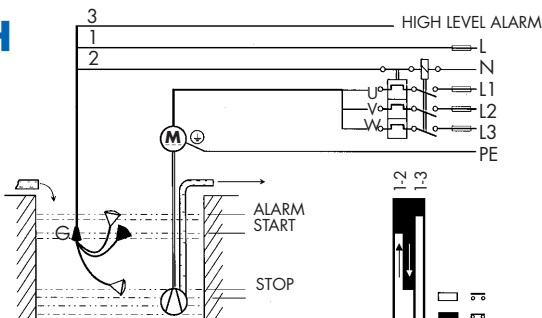

WIRING FOR EMPTYING + HIGH LEVEL ALARM
SCHALTUNG FÜR ENTLEREEN + ALARM OBEN
COUPLAGE DE VIDANGE + ALARME HAUTE

3L

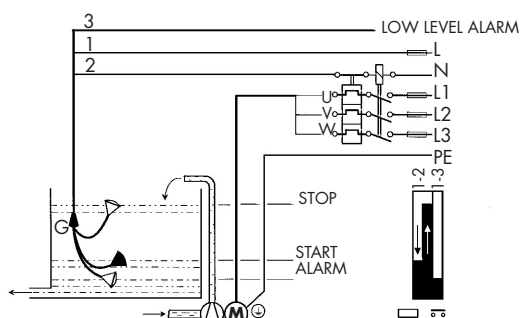

WIRING FOR FILLING + LOW LEVEL ALARM
SCHALTUNG FÜR FÜLLEN + ALARM UNTEN
COUPLAGE DE REPISSAGE + ALARME BASSE

If our standard switches do not meet your specific needs, we

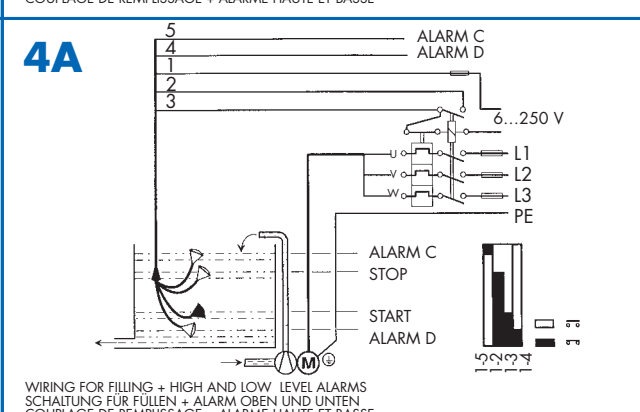
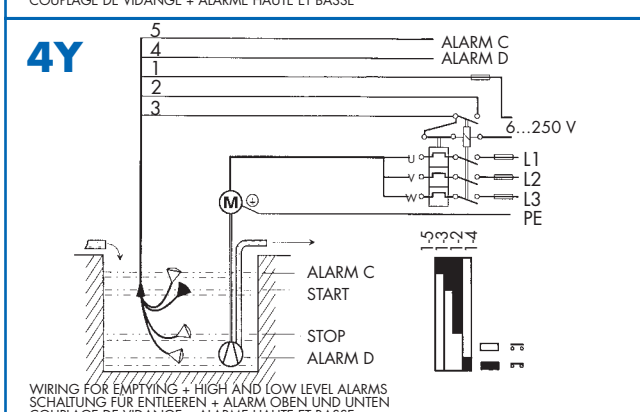
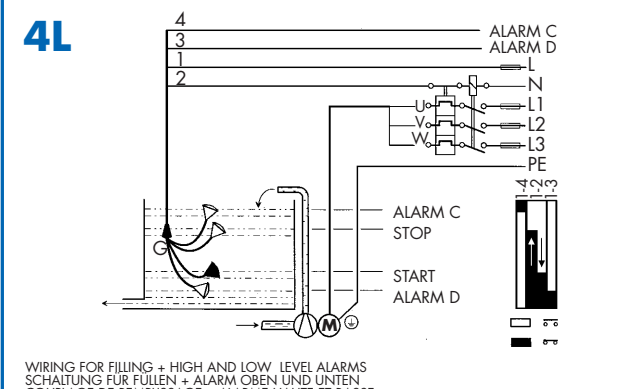
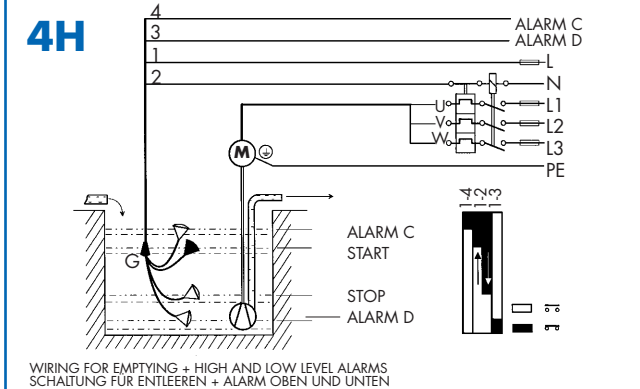
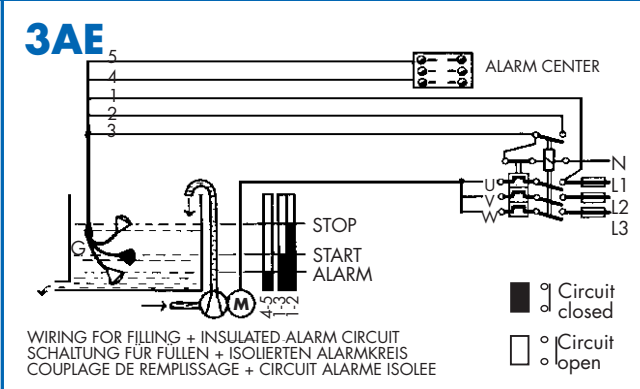
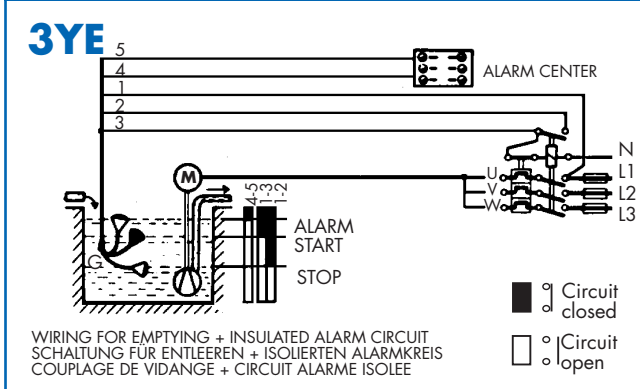
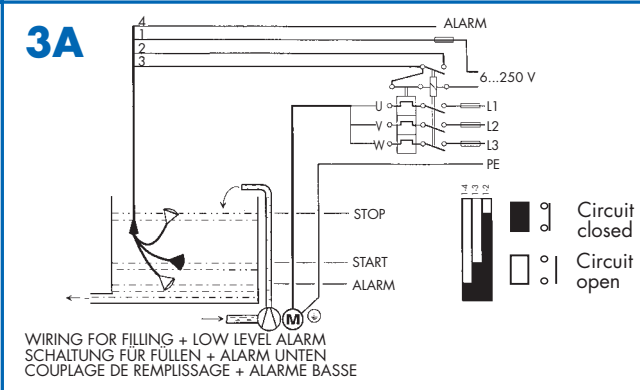
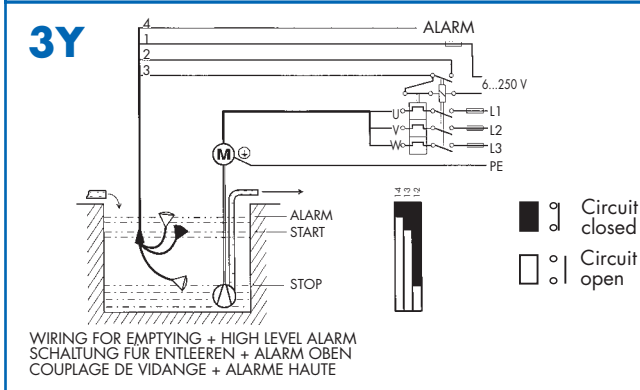
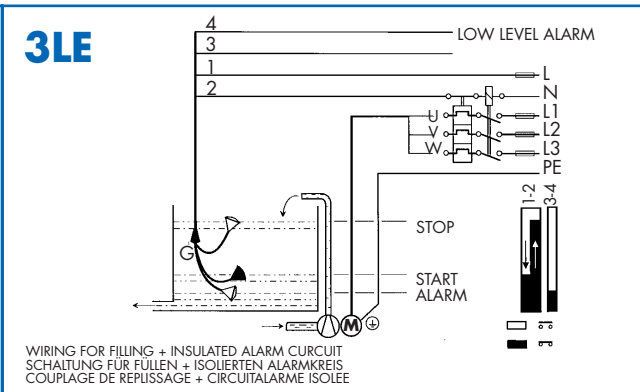
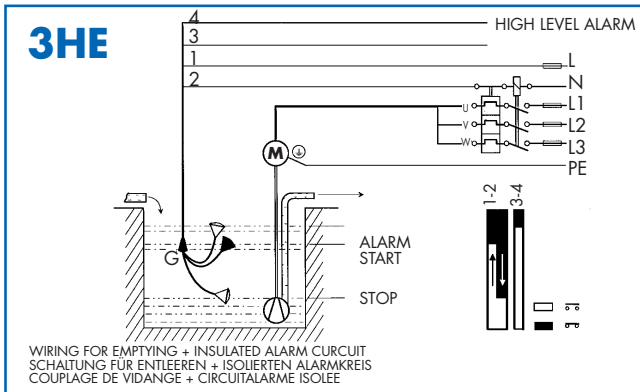

design a non-standard Float Switch to your requirements.

KARI KARI MINI FLOAT

The Kari Mini Float Switch is a control device for filling and discharging pumps, motor and magnetic valves. It is also an alarm device at certain pre-determined surface levels. The Finnish Electrical Inspectorate, one of the most careful in Europe, has performed the tests according to the all-European CCA-agreement, and approved the Kari Mini Float Switch for use in non-flammable liquids at 250 Volts. For its small size ($\varnothing 76$ mm) the Kari Mini Float can be used in narrow places.



STANDARD MINI SWITCH FLOATS $\varnothing 76$ mm



TYPE	OPERATION	TYPE	OPERATION
M1H	High level alarm or magnetic valve control	M2H	Discharging pump control or dry running prevention
M1L	Low level alarm or magnetic valve control	M2L	Charging pump control
M1C	Change over contact (alarms etc.)		

KARI MINI FLOAT SWITCHES, CIRCUIT DIAGRAMS

<p>M1H</p> <p>ALARM FROM HIGH LEVEL ALARM VON DER OBERE HÖHE ALARME HAUTE</p>	<p>M1L</p> <p>ALARM FROM LOW LEVEL ALARM VON DER UNTERE HÖHE ALARME BASSE</p>
<p>M2H</p> <p>WIRING FOR EMPTYING OF SUBSOIL WATER PUMPS ETC. SCHALTUNG FÜR ENTLÉEREN VON GRUNDWASSERBRUNNEN COUPLAGE DE VIDANGE P. EX. POUR PUITES ARTESIENS</p>	<p>M2L</p> <p>WIRING FOR FILLING OF STORAGE TANKS, ETC. SCHALTUNG FÜR FÜLLEN VON LAGERBEHÄLTER USW. COUPLAGE DE REMPLISSAGE P. EX. POUR RÉSERVOIRS DE STOCKAGE</p>
<p>M1C</p> <p>CHANGE OVER SWITCH</p>	

Kari Mini Float Dimensions

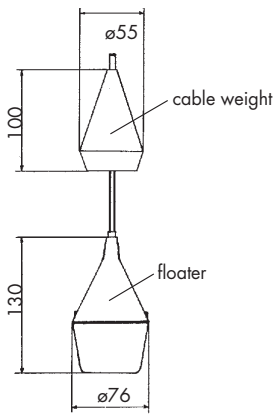

Switching height differential in relationship to the weight from the float.

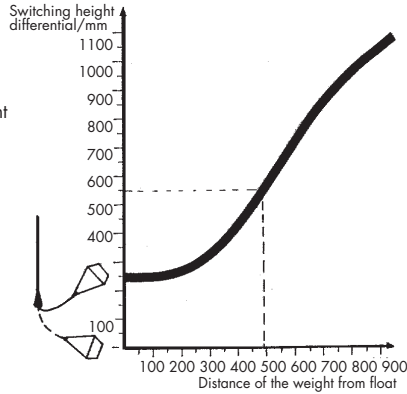

If the weight is set 48 cm apart from the float, the switching height differential is about 55 cm.

THE FOLLOWING INFORMATION SHOULD BE GIVEN WHEN ORDERING

- type or special requirements
- cable length if more than 5 meters
- height differential between upper and lower levels if smaller than 250 mm or greater than 1200 mm. (Min. 50 mm, max 2000 mm, but not available in the same float)

If the viscosity of the liquid is high, we recommend an extra weight on the cable. Suitable auxiliary weights, which we supply to order, are as follows.

- Weight G**  **black, 400 g**
- Weight H**  **red, 700 g**
- Weight I**  **grey, 1000 g**

Weights are tightened onto the cable with a wedge

TECHNICAL INFORMATION for Standard and Mini Float Switches

Switching element	micro switch
Rated voltage	6...250VAC
Rated current	6AAC1, 3AAC3
Pressure rating	200 kPa (2kp/m ²)
Heat rating	+55 C°
Range of adjustment (standard)	20 cm to 120 cm
Special ranges	.5 cm-10 cm, 10 cm-20 cm, 1,2 m-2 m

Standard cable length	5 m
Weight	0.55 kg to 2 kg according to type
Buoyancy (standard)	6 N (600 g)
Buoyancy (mini floats)	2 N (200 g)
Float material	Polypropen (PP)
Cable insulation	PVC (standard)
by request:	Polyurethane, Rubber (Aton) Polyethylene or Teflon

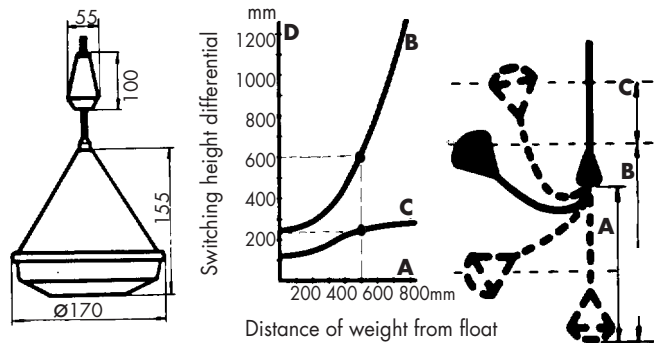

Curve B shows the switching height differential of the Kari Float Switch in relationship to the distance of the weight from the float. Curve C shows the equivalent differential between starting and alarm levels. For example: if the weight of model 3H is 50 cm from the bottom of the float (measure A), the start/stop differential is about 60 cm and the start/alarm differential is about 25 cm.

APPROVALS:   File no. LR 90200-26
NRTL/C

OTHER KARI PRODUCTS



Alarm device for barrels

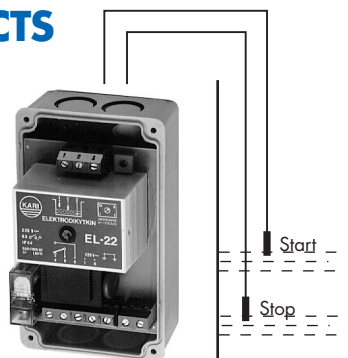

EL-22 Electrode switch for conductive liquids

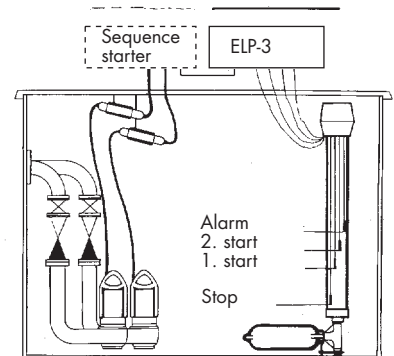

ELP-SYSTEM Level controllers for waste water



INGENIEROS ASOCIADOS DE CONTROL, S. L.

Telf. 913831390

comercial@iac-sl.es