

Stainless Steel, 1/2"-2"

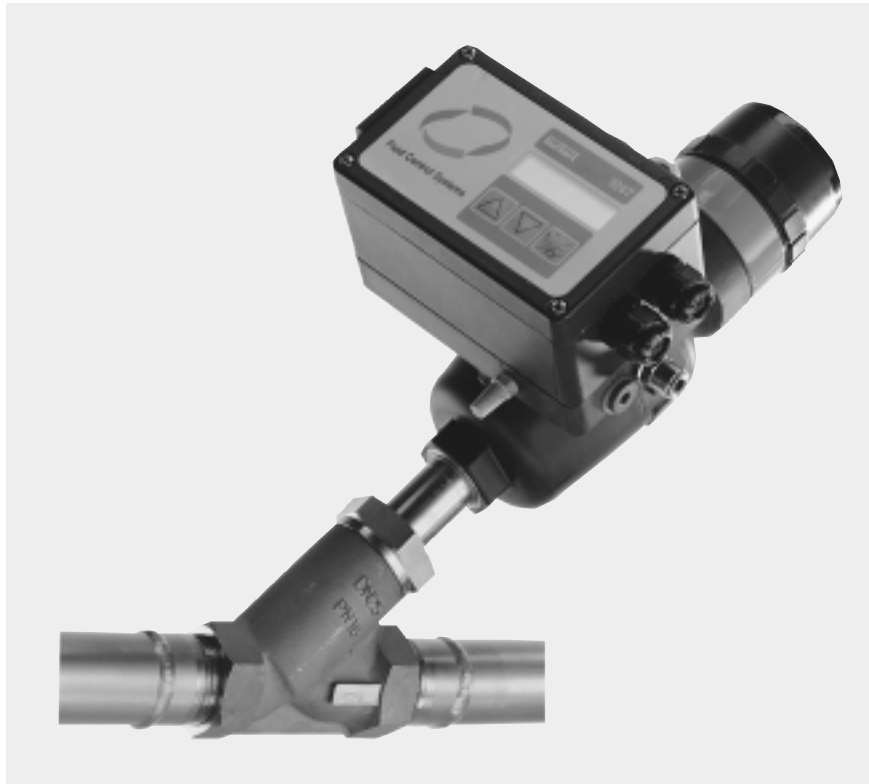

Advantages / Benefits

- ▶ Ultra compact design
- Low weight
- ▶ Automatic self-adjustment
of basic parameters
- ▶ Integrated PID controller
- ▶ User-friendly operation
- LCD display
- Keypad interface
- Easy-to-understand
menu-guided
programming
- ▶ Code protection against
unauthorized access
- ▶ Maintenance-free
packing glands
- ▶ CE certified

Design

The Type 2632 is a stainless steel control valve with an electropneumatically operated positioner. The Type 1067 positioner consists of three main parts: the valve stem position pickup, the electropneumatic control system and the micro-processor electronics. The valve stem position pickup, a linear potentiometer connected to the valve stem, feeds back the actual stem position to the positioner electronics. The micro-processor electronics compares the actual stem position to the set point given by a standard signal (4-20mA, 0-10V,...). In the case of a position difference, the electropneumatic control system corrects the stem position until the set point is reached. The Type 1067 positioner also features a built-in process controller for the control of flow, temperature, pressure, etc.

- Programmable flow curves:
 - linear
 - equal percentage
 - freely programmable
- No air consumption at steady-state conditions
- Excellent flow characteristic combined with high flow rates
- Integrated PID-Controller
- Captured exhaust air
- Direct mounting, no tubing between positioner and valve
- Flanged, NPT or Tri-Clamp® connections

Applications

- Textile dyeing and bleaching
- Food processing
- Chemical industry
- Water treatment
- General processing industry



INGENIEROS ASOCIADOS DE CONTROL S.L.

Telf.: 913831390
comercial@iac-sl.es

Technical Data Positioner Type 1067

Electrical Data

Voltage supply:	24 V DC
Power consumption:	< 10 W
Signal input for positioner:	Unit signal: 4–20 mA 0–20 mA 0–10 V
Binary input:	Configurable as normally open or closed contact
Connection:	Terminal strip Cable gland 2 x PG 9

Pneumatic Data

Instrument air:	Filtered compressed air, lubricated or non-lubricated
Air performance	
Air inlet valve:	$C_v = .035$
Exhaust valve:	$C_v = .04$
Internal air consumption at steady-state condition:	Zero
Connection:	Female pipe thread, G 1/8"

Positioner Data

Overall dimensions:	5" x 3.2" x 3"
Body material:	Aluminum, laquered
Fluid plate material:	Aluminum, anodized
Weight of positioner:	Approx. 2.2 lbs
Rating:	NEMA 4 (IP 65)
Operating temperature:	32°F to 140°F

Technical Data Control Valve 2632

Valve

Size:	1/2", 3/4", 1", 1-1/4", 1-1/2", 2"
Connection:	150# ANSI raised face flange, NPT, Tri-Clamp®
Control range:	More than 50:1
Flow characteristic:	Modified equal percentage
Flow capacity:	See table below
Fluid temperature:	+14°F to +356°F
Max. Operating pressure:	230 PSI (at ambient temperature)

Actuator

Actuator piston dia.:	See table page 4 or 6
Supply pressure:	65 PSI, min. 85 PSI, max.
Function:	Normally closed. Flow-direction under seat.
Leakage class:	According to ANSI B 16-104 Class IV (Stainless steel seat and stainless steel plug)

Specifications - Flow Capacity

Plug travel [%]	C_v -value					
	1/2"	3/4"	1"	1-1/4"	1-1/2"	2"
0	0.00	0.00	0.00	0.00	0.00	0.00
10	0.07	0.15	0.47	1.17	2.21	3.50
20	0.17	0.37	1.28	3.03	6.52	10.49
30	0.33	0.93	2.45	5.94	11.77	18.64
40	0.51	1.86	4.19	10.02	20.04	30.29
50	0.77	3.03	7.12	16.08	28.08	40.78
60	1.19	4.31	10.83	22.14	34.02	48.93
70	1.79	5.59	13.86	24.47	39.03	57.09
80	2.53	6.76	15.73	25.63	41.36	64.08
90	3.51	8.16	16.54	26.80	42.87	67.57
100	4.43	8.50	16.89	27.38	43.12	69.90

Functional Diagram

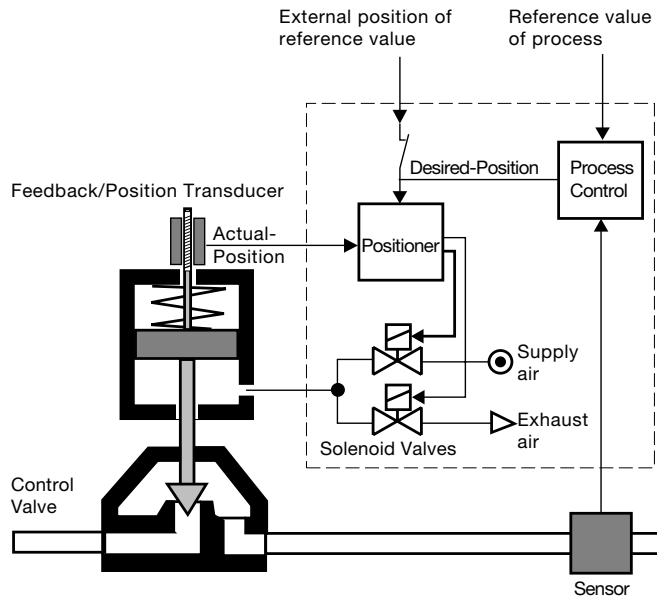

Material

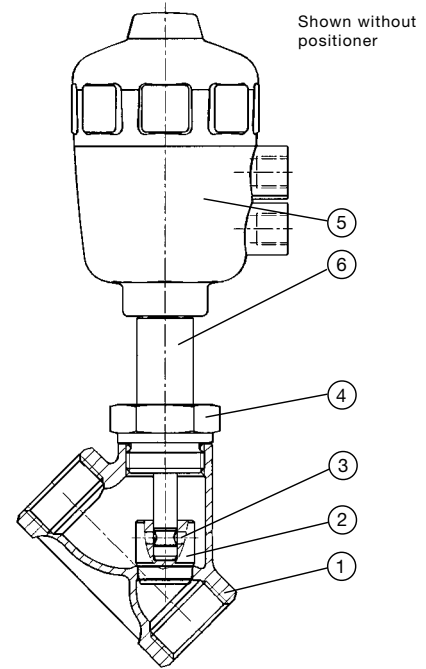

- 1 Valve body: 316 SS
- 2 Plug and stem: 316 SS or 316 SS and PTFE
- 3 Pin: 316 SS
- 4 Valve bonnet: 316 SS
- 5 Actuator: Polyamide
- 6 Packing glands: PTFE
Packing box: 316 SS

Ordering Chart

Orifice Size [inch]	Actuator Piston dia. [inch]	Max. Oper. Pressure [PSI]	Seal	Item No. for Different Connections								
				Threaded Port			Tri-Clamp		150# ANSI Flange			
				[NPT]	Item No.	Weight [lbs]	Tube O.D. [inch]	Item No.	Weight [lbs]	Pipe Size [inch]	Item No.	Weight [lbs]
1/2	2.48	230	S.St./S.St. S.St./PTFE	1/2	430 687 W 416 167 J	5.9	—	—	—	1/2	425 611 Q 425 603 Z	9.3
3/4	2.48	230	S.St./S.St. S.St./PTFE	3/4	430 686 V 416 168 T	6.4	3/4	USO 510 9 USO 511 0	6.4	3/4	425 612 R 425 604 S	10.8
1	3.15	230	S.St./S.St. S.St./PTFE	1	420 666 E 416 169 U	8.8	1	420 678 J 416 131 E	8.8	1	425 613 J 425 605 T	14.3
1-1/4	3.15	230	S.St./S.St. S.St./PTFE	1-1/4	420 667 F 416 170 Z	11.9	1-1/4	420 679 K 416 132 F	11.9	1-1/4	425 614 K 425 606 U	19.6
1-1/2	3.94	175	S.St./S.St. S.St./PTFE	1-1/2	420 666 Q 416 171 N	15.0	1-1/2	420 680 H 416 133 G	15.0	1-1/2	425 615 L 425 607 V	23.8
2	3.94	140	S.St./S.St. S.St./PTFE	2	420 669 R 416 172 P	17.8	2	420 681 W 416 134 H	17.8	2	425 616 M 425 608 E	28.9

Dimensions [inch]

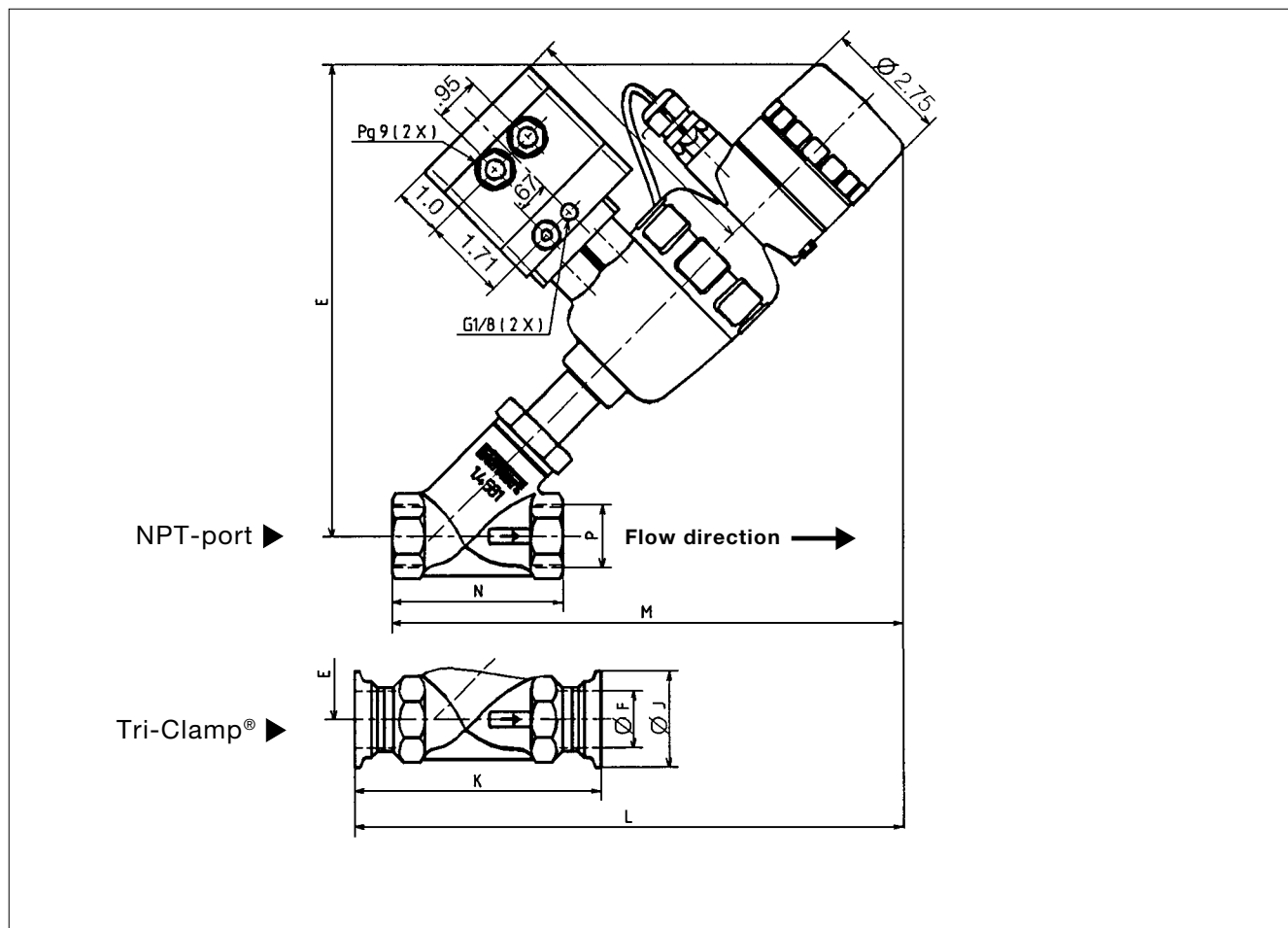

Variable dimensions [inch]

P (NPT)	Actuator Piston dia.	C	E	øF	øJ	K	L	M	N
1/2	2.48	5.48	9.57	0.71	1.34	4.18	11.15	10.60	3.11
3/4	2.48	5.48	9.69	0.93	1.99	4.69	11.31	10.68	3.43
1	3.15	5.79	10.52	1.17	1.99	5.12	12.21	11.66	4.10
1 1/4	3.15	5.79	10.76	1.51	1.99	5.95	13.04	12.41	4.73
1 1/2	3.94	6.30	12.81	1.75	2.52	6.15	15.76	15.05	4.73
2	3.94	6.30	13.36	2.17	3.05	7.88	17.02	16.04	5.87

50% More Economical Than Conventional Control Valves

Easy Pressure Control
Flow Control
Temperature Control

Easy
to calibrate

Automatic self-adjustment of basic parameters by finger tip control

Easy
to operate

- User-friendly operation
- LCD and key pad interface
 - Menu-guided programming
 - Programmable characteristic curves

Easy
to install

- Compact design
- Delivered pre-mounted, tested and ready to install
 - Requires less space than conventional control valves

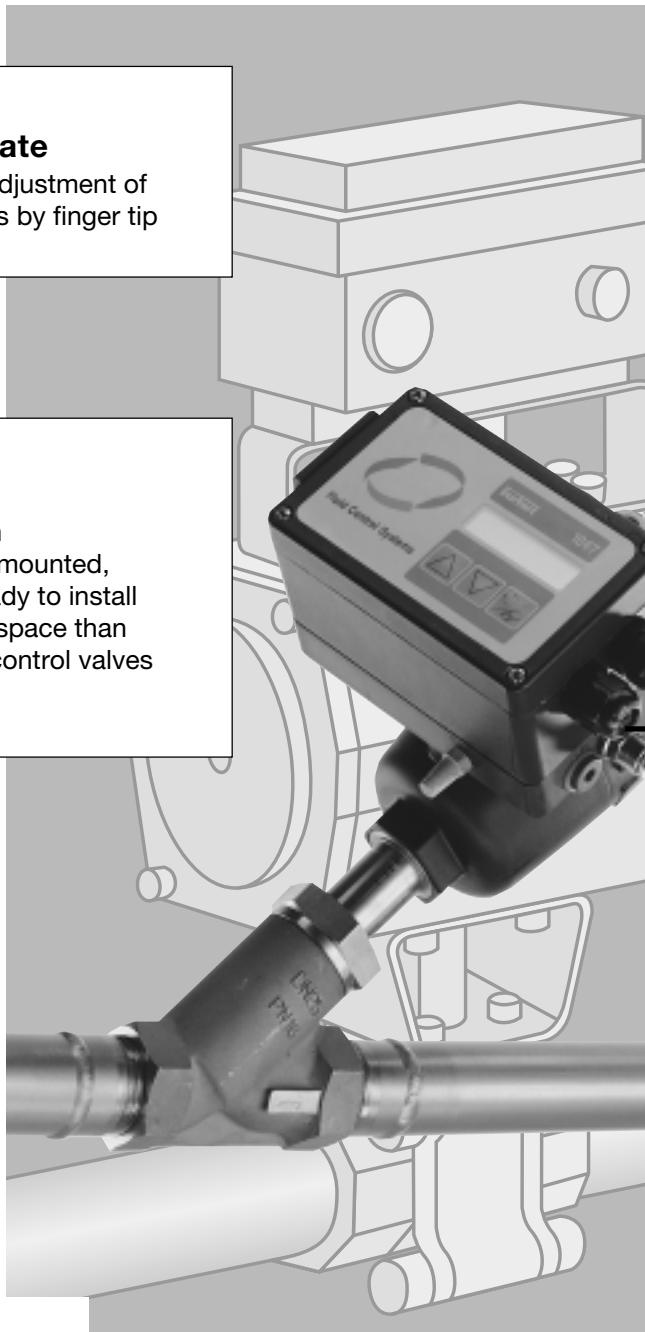

Burkert Link

Easy
to operate



Burkert control valve with Burkert digital flow transmitter for proportional process control.



INGENIEROS ASOCIADOS DE CONTROL S.L.

Tel.: 913831390
comercial@iac-sl.es

Dimensions [inch]

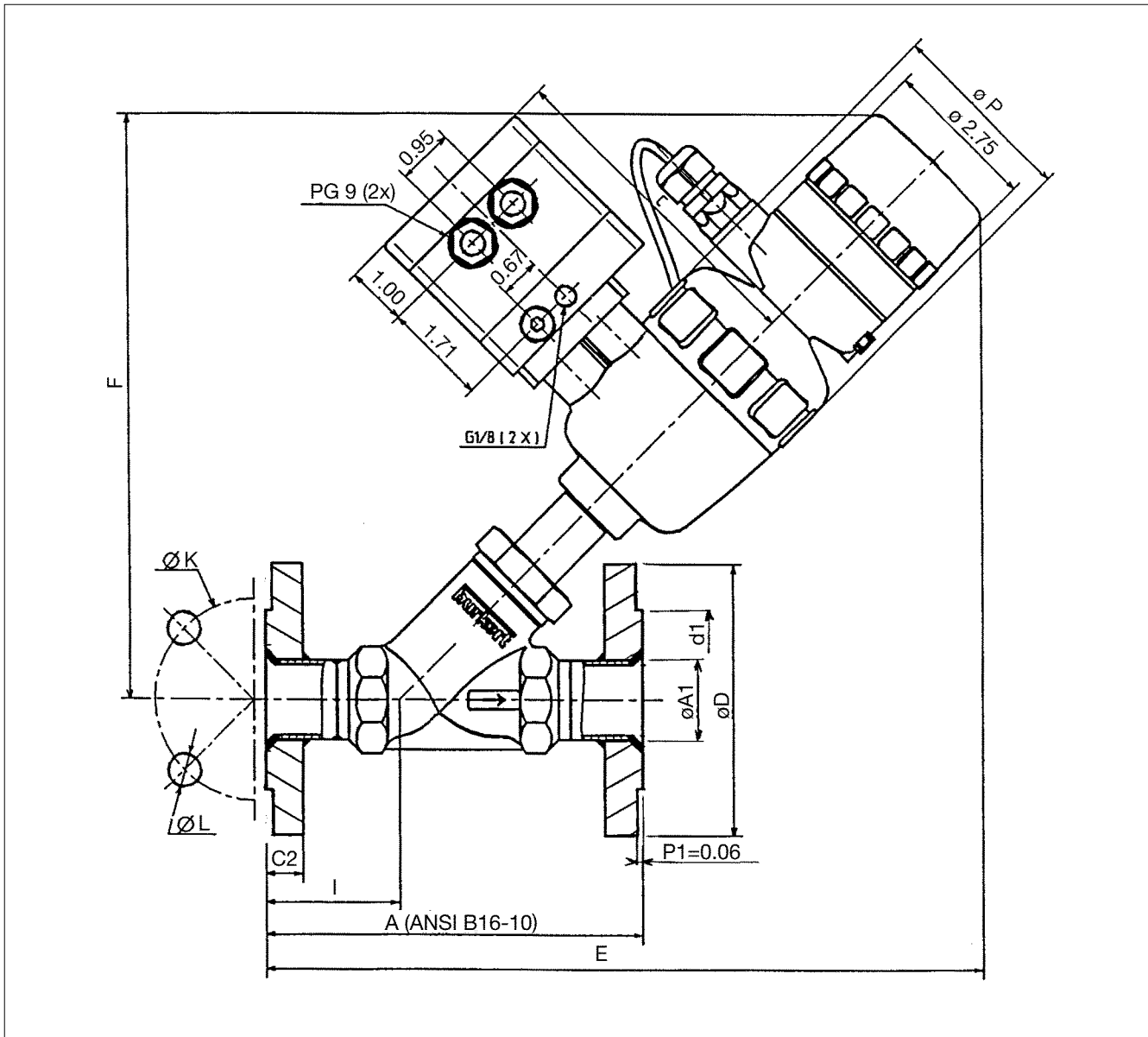

Variable dimensions [inch]

Size	Actuator piston dia.	A	A1	D	C	P	E	F	C2	I	K	L	d1
1/2	2.48	5.52	0.84	3.51	5.48	3.15	11.31	9.57	0.47	1.73	2.38	0.62	1.38
3/4	2.48	5.99	1.06	3.90	5.48	3.15	11.94	9.69	0.55	2.23	2.75	0.62	1.69
1	3.15	6.50	1.33	4.26	5.79	3.98	12.81	10.52	0.63	2.27	3.13	0.62	2.00
1 1/4	3.15	7.01	1.67	4.61	5.79	3.98	13.63	10.76	0.71	2.64	3.50	0.62	2.50
1 1/2	3.94	7.49	1.90	5.00	6.30	5.00	16.43	12.81	0.75	2.76	3.88	0.62	2.88
2	3.94	8.51	2.38	5.99	6.30	5.00	17.61	13.36	0.83	3.03	4.75	0.75	3.63