

# Differential Pressure Gauge

With Integrated Working Pressure Gauge and Micro Switch

## Pressure Gauges

**DELTA-comb** with Component Approval

Model 702.03.100

- Working pressure gauge integrated as a standard feature enables the central monitoring of differential pressure and working pressure in one measuring instrument
- One or two adjustable microswitches respectively
- High repeatability of the switchpoints
- High working pressure (static pressure) 25 bar
- Overload value either side 25 bar
- Solid case construction for protection against external mechanical effects
- Three cast-on mounting brackets for wall mounting
- Long service life
- Component approval to ensure flow protection in accordance with DIN 32 727 Reg.-No.: 1B0162000, and also to safeguard flow in steam boilers in accordance with VdTÜV note of instructions "flow 100", component sign number TÜV.SW.00-030



**DELTA-comb** with 2 micro switches, terminal box (optional extra) and compression fitting with ferrule (optional extra)

### General features

These differential pressure gauges are particularly intended for flow safeguarding in heat transfer oil plants according to DIN 32 727 and in hot-water apparatus according to VdTÜV note of instructions "flow 100". This gauge has been designed for connection to standard throttling devices (e.g. orifice gauges, nozzles or similar) that operate according to the differential pressure principle and are interconnected via differential pressure lines and shut-off devices.

Apart from the display of the differential pressure, these applications require, as a rule, the display of the current working pressure. For this reason, a working pressure gauge is integrated in the differential pressure gauge **DELTA-comb** as a standard feature. An additional measuring point involving additional expenses for piping and mounting is thus no longer required.

The white dial of the working pressure gauge distinctly stands out against the blue background of the display of the differential pressure gauge, thus enabling a quick and safe reading of both quantities to be measured.

The ranges of 0 ... 250 mbar up to 0 ... 6 bar provide the measuring ranges required for the applications mentioned above. The sturdy and compact design of the differential pressure gauge makes it possible to use it even under tough industrial ambient conditions.

### Supplementary data sheets

- Differential pressure gauge with integrated working pressure gauge Model 702.01.100 (see data sheet PM 07.15) **DELTA-plus**
- Differential pressure gauge with integrated working pressure gauge and microswitch Model 702.02.100 (see data sheet PM 07.16) **DELTA-comb**
- Differential pressure switch Model 851.02.100 (see data sheet PM 07.17) **DELTA-switch**
- Differential pressure transmitter Model 891.34.2189 (see data sheet PM 07.18) **DELTA-trans**

## Design and operating principle

Pressure  $p_1$  and  $p_2$  are given in the  $\oplus$  and  $\ominus$  measuring medium chambers separated by an elastic diaphragm (1).

The differential pressure ( $\Delta p = p_1 - p_2$ ) causes axial movement (measuring travel) of the diaphragm against the measuring range spring (2).

The transmission of the differential pressure proportional to the measuring travel to the movement (4) within the indicating case and to the plungers of the microswitches (5) and is carried out pressure sealed and with little friction by means of a connecting rod (3).

The overpressure protection is provided by contoured metal bolsters for the elastic diaphragm (6).

The adjustment of the switchpoint is made by setpoint screws accessible from the front (7). The assistant scales (8) enable a relatively accurate adjustment of the switchpoints over  $270^\circ$  and indicate the setpoint that is momentarily adjusted.

## Illustration of operating principle

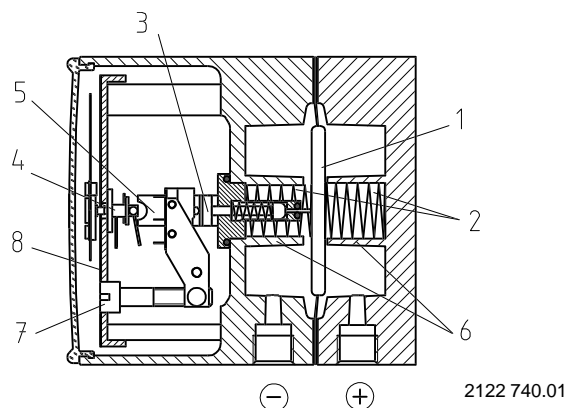

## Technical data

### Nominal size

Differential pressure gauge:  $\varnothing$  100 mm  
Working pressure gauge:  $\varnothing$  23 mm

### Accuracy class

Differential pressure gauge: 2.5  
Working pressure gauge: 4

### Scale ranges per EN 837

Differential pressure: 0 ... 0.25 to 0 ... 6 bar  
Working pressure: 0 ... 25 bar

### Working pressure max. (static pressure)

25 bar

### Overpressure safety

Either side max. 25 bar

### Operating temperature

Ambient:  $-10 \dots +70^\circ\text{C}$   
Medium:  $+90^\circ\text{C}$  maximum

### Ingress protection

IP 54 per EN 60 529 / IEC 529

### Measuring media chamber (exposed to pressure medium)

GD-ALSi 12 (Cu) 3.2982, black painted

### Pressure connections (exposed to pressure medium)

2 x G  $\frac{1}{4}$  female, bottom, in-line,  
axle base 26 mm

### Pressure elements (exposed to pressure medium)

Differential pressure: Compression spring of stainless steel 1.4310  
and separating diaphragm of FPM/Viton  
Working pressure: Bourdon tube Cu-alloy

### Links (exposed to pressure medium)

Stainless steel 1.4104, FPM/Viton

### Sealing rings (exposed to pressure medium)

FPM/Viton

### Movement

Cu-alloy, wear parts German silver

### Dial

Differential pressure gauge: blue aluminium with white lettering  
Working pressure gauge: white plastic with black lettering

### Pointer

Differential pressure gauge: white aluminium adjustable pointer  
Working pressure gauge: black plastic

### Zero adjustment for differential pressure gauge

By means of adjustable pointer

### Case

GD-ALSi 12 (Cu) 3.2982, black painted

### Window

acrylic

### Weight

approx. 1.4 kg

### Gauge mounting

Pressure entries identified  $\oplus$  and  $\ominus$ ,

$\oplus$  high pressure,  $\ominus$  low pressure

Mounting by means of rigid tailpipes or wall mounting with mounting brackets

### Electrical contact

Contact type	Micro switch	
		1 x SPDT
Contact functions	850.3	850.3.3

Load data	Voltage AC		
	U max.	250 V	
	I max.	1.4 A	
	P max.	250 VA	
Switching point adjustment	from the outside at assistant scale by means of setpoint screw(s)		
Setting range	from 10 % to 100 % of span		
Switching point repeatability accuracy	$\leq 1.6\%$		
Contact hysteresis	max. 5 % of full scale value (optional 2.5 % max.)		
Wiring	Cable gland M16x1.5 with 1 m connected cable		

### Optional extras

- Pressure media chamber GD-ALSi 12 (Cu) HART-COAT surface protection
- Pressure media chamber of stainless steel (without working pressure gauge)
- Accuracy class 1.6 for differential pressure gauge with factory-set switching points for ranges from 0 ... 1 bar to 0 ... 6 bar (switching direction to be specified)
- 4-way valve manifold Cu-alloy or stainl. steel (1x pressure equalising valve, 2x pressure gauge valve, 1x valve for purging or air bleeding)
- Other threaded pressure connections female or male
- Compression fitting with ferrule for pipe  $\varnothing$  6, 8 or 10 mm
- Front flange for panel mounting
- Wiring with terminal box, cable gland M20x1.5 or L-plug
- Approval German Lloyd, No. 40 146 - 01 HH

Dimensions in mm

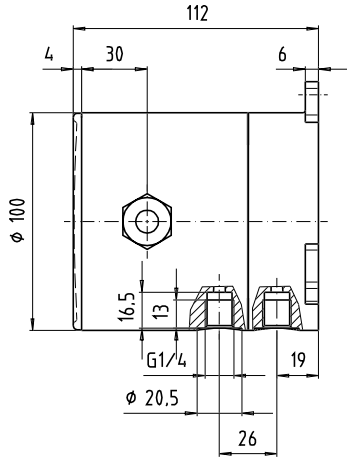

2123 568.01

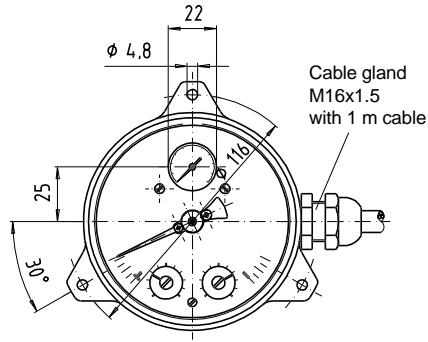

Electrical connection details

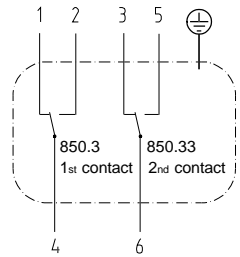

4-way valve manifold as optional extra

Lead sealing of the set switching points

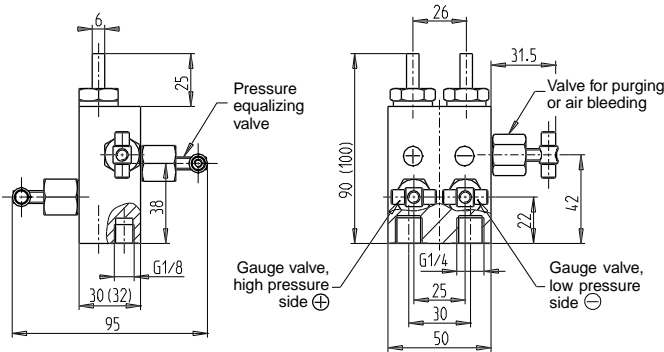

Dimensions in clamps: stainless steel version

2261 821.02

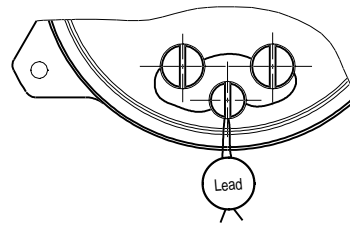

2238 276.04

Panel mounting as optional extra

Wiring versions as optional extra

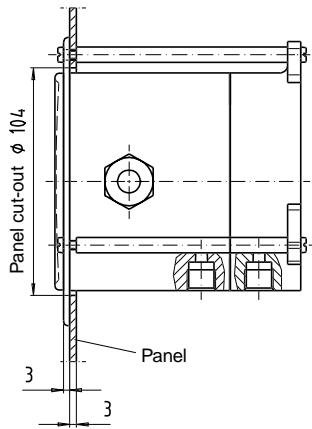

2157 306.02

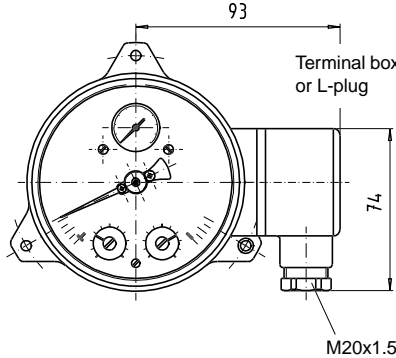

M20x1.5

Electrical connection details

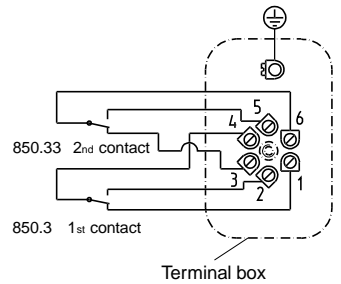

2162 679.01

Ordering information for Differential Pressure Gauge with integrated working pressure gauge and micro switch **DELTA-comb** with component approval Model 702.03.100

Field No.	Code	Instrument design
1	[ ]	<b>Unit</b>
		<b>B</b> bar
	<b>?</b> other	
	<i>Please state as additional text</i>	
	<b>Measuring range</b>	
	<b>AN</b>	0 ... 0.25 bar
	<b>BB</b>	0 ... 0.4 bar
	<b>BC</b>	0 ... 0.6 bar
	<b>BD</b>	0 ... 1 bar
	<b>BE</b>	0 ... 1.6 bar
<b>BF</b>	0 ... 2.5 bar	
<b>BG</b>	0 ... 4 bar	
<b>BH</b>	0 ... 6 bar	
2	[ ]	<b>??</b> other
		<i>Please state as additional text</i>

Field No.	Code	Instrument design	
		<b>Process connection</b>	
	AA	2 x G 1/4 female <i>standard</i>	
	AM	2 x G 1/4 B Cu-alloy	
	AN	2 x G 1/4 B stainless steel	
	DA	compression fitting with ferrule, steel for pipe Ø 6 mm	
	DB	compression fitting with ferrule, steel for pipe Ø 8 mm	
	DC	compression fitting with ferrule, steel for pipe Ø 10 mm	
	DE	compression fitting with ferrule, stainless steel for pipe Ø 6 mm	
	DF	compression fitting with ferrule, stainless steel for pipe Ø 8 mm	
	DG	compression fitting with ferrule, stainless steel for pipe Ø 10 mm	
	DK	compression fitting with ferrule, Cu-alloy for pipe Ø 6 mm	
	DL	compression fitting with ferrule, Cu-alloy for pipe Ø 8 mm	
	DM	compression fitting with ferrule, Cu-alloy for pipe Ø 10 mm	
3	??	other <i>Please state as additional text</i>	
		<b>Pressure media chamber</b>	
	A	aluminium, black painted <i>standard</i>	
	H	aluminium HART-COAT	
	C	stainless steel <i>version without working pressure gauge</i>	
4	?	other <i>Please state as additional text</i>	
		<b>Separation diaphragm / Sealing rings</b>	
5	J	FPM/Viton	
		<b>Accuracy class for differential pressure gauge</b>	
	4	class 2.5 <i>standard</i>	
6	3	class 1.6 <i>scale ranges 0 ... 1 bar and up</i> <sup>1)</sup>	
		<b>Mounting flange / bracket</b>	
	Z	without <i>standard</i>	
	D	front flange, black steel	
7	?	other <i>Please state as additional text</i>	
		<b>Ingress protection</b>	
	F	IP 54 <i>standard</i>	
8	I	IP 65	
		<b>Alarm contacts</b>	
	E	1 SPDT micro switch (850.3) <i>standard</i>	
9	D	2 SPDT micro switches (850.3.3)	
		<b>Wiring</b>	
	1	cable gland M16x1.5 with 1 m connected cable <i>standard</i>	
	P	terminal box M20x1.5	
	G	L-plug 3-pin + PE <i>(with 1 contact)</i>	
	N	L-plug 6-pin + PE <i>(with 2 contacts)</i>	
10	?	other <i>Please state as additional text</i>	
		<b>Valve manifold / Pressure equalizing valve</b>	
	Z	without <i>standard</i>	
	M	4-way valve manifold, Cu-alloy	
11	V	4-way valve manifold, stainless steel	
		<b>Approvals</b>	
	G	with GL-approval	
12	V	component-approved (flow protection DIN 32 727 and VdTUV note of instructions "flow 100")	
		<b>Additional order details</b>	
	YES	NO	
13	1	Z	quality certificates <i>Please state in clearly understandable text !</i>
14	T	Z	additional text <i>Please state in clearly understandable text !</i>

1) with factory-set contacts, please specify switching points and switching direction as additional text

Order code for **DELTA-comb** with component approval Model 702.03.100

	1	2	3	4	5	6	7	8	9	10	11	12	13	14
702.03-E	-		-		-	J							-	

Additional text: \_\_\_\_\_



INGENIEROS ASOCIADOS DE CONTROL S.L.

Tel.: 913831390  
comercial@iac-sl.es