

Digital Temperature Transmitter

Universally Programmable, Head Mounting

Electronic Temperature Measurement

Standard • Model T12.10.000

⊕-class protection EEx ia • Model T12.10.002

⊕-class protection EEx ib • Model T12.10.004

- Universally programmable for
 - RTDs
 - Thermocouples
 - Resistance-sensor
 - mV-sensor
- Output linear to temperature with input signal from RTDs and thermocouples
- Analogue output 4 ... 20 mA, invertable, 2 wire design
- Signalling configurable for sensor burnout and sensor short circuiting
- ⊕ class protection, intrinsically safe
 - II 1 G EEx ia IIB/IIC T4/T5/T6
 - II 2 G EEx ib IIB/IIC T4/T5/T6
- Isolation voltage 1500 VAC between sensor and current loop
- 100% Rh protection, moisture condensation permissible
- Increased ambient temperature
- PC-configurable, Windows-programme
- CE - Conformity



Important features of the T12 transmitter range

The digital temperature transmitter T12 range is designed for universal industrial use.

Comprehensive configuration possibilities like, for example, type of sensor, measuring range and error signalling, reliable accuracy, galvanic isolation and EMI protection characterize these transmitters. The compact head mounting case fits in almost any DIN connecting head with form B.

During configuration any one of 17 types of sensors can be selected. Measured temperatures are from - 200 °C up to + 2300 °C.

The following sensors can be connected:

- RTDs per DIN IEC 751, JIS C 1606, DIN 43 760 in 2-, 3- and 4-lead connection, the connection-system used is configurable and ensures an optimal lead wire compensation
- thermocouples per DIN IEC 584, DIN 43 710 and ASTM E988 Cold junction compensation (CJC) is built-in, the use of an external CJC is selectable via configuration.
- resistance-sensors up to 5000 Ω in 2-, 3- and 4-lead connection, configurable compensation of the connection cable
- mV-sensors up to 800 mV

Configuration is done by means of a standard DOS PC using the Configuration-Set. With the Configuration Software the required parameters are defined. Data to the T12 is down loaded using a Communication-Interface (Programming Unit). The bi-directional communication enables displaying the measured values on the PC. Configuration sets are available as an optional extra.

The transmitters are delivered with a basic configuration (see order information). Alternatively, upon request, transmitters can be delivered with a customized configuration within the given limits.

Specification

Model T12.10.000 / T12.10.002 / T12.10.004

Input	configurable: type of sensor and measuring range	max. measuring range	minimum measuring span ¹⁾	
RTDs	Pt 100	DIN IEC 751	-200 ... + 850 °C	25 K
	JPt 100	JIS C 1606	-200 ... + 500 °C	25 K
	Ni 100	DIN 43760 : 1987-09	-60 ... + 250 °C	25 K
thermocouple	type T, Cu-CuNi	DIN IEC 584	-200 ... + 400 °C	50 K
	type E, NiCr-CuNi	DIN IEC 584	-100 ... +1000 °C	50 K
	type J, Fe-CuNi	DIN IEC 584	-100 ... +1200 °C	50 K
	type L, Fe-CuNi	DIN 43710 : 1985-12	-100 ... + 900 °C	50 K
	type K, NiCr-Ni	DIN IEC 584	-180 ... +1372 °C	50 K
	type N, NiCrSi-NiSi	DIN IEC 584	-180 ... +1300 °C	100 K
	type U, Cu-CuNi	DIN 43710 : 1985-12	-200 ... + 600 °C	75 K
	type R, PtRh-Pt	DIN IEC 584	-50 ... +1760 °C	200 K
	type S, PtRh-Pt	DIN IEC 584	-50 ... +1760 °C	200 K
	type B, PtRh-PtRh	DIN IEC 584	0 ... + 1820 °C ²⁾	200 K
	type W3, W3Re/W25Re	ASTM E988	0 ... + 2300 °C	200 K
	type W5, W5Re/W26Re	ASTM E988	0 ... + 2300 °C	200 K
	resistance-sensor		0 ... 5000 Ω	30 Ω
mV-sensor		-10 ... 800 mV	5 mV	
RTDs / resistance-sensor				
measuring deviation per	DIN IEC 770, 23 °C ± 5 K			
	RTDs	± 0.2 K or ³⁾ ± (0.025 % FS + 0.1) K		
	resistance-sensor	± 0.07 Ω or ³⁾ ± 0.03 % FS in Ω		
sensor current		approx. 0.2 mA		
temperature coefficient T_C	RTDs	± (0.025 % FS + 0.09) K / 10 K _{Tamb}		
	resistance-sensor	± (0.025 % FS + 0.01) Ω / 10 K _{Tamb}		
lead wire connection		configurable: 2-lead , 3-lead , 4-lead		
connection leads	effect	± 0.02 Ω / 10 Ω		
	max. permissible resistance	30 Ω each wire, 3-lead symmetric		
signalling of sensor error		configurable		
thermocouples				
measuring deviation ⁴⁾ per	DIN IEC 770, 23 °C ± 5 K	± 0.5 K or ³⁾ ± 0.05 % FS or ³⁾ ± 10 μV		
cold junction compensation		± 1.0 K		
temperature coefficient T_C	type T, E, J, L, K, N, U	± (0.05 % FS + 0.1) K / 10 K _{Tamb} or ³⁾ ± 0.5 K / 10 K _{Tamb}		
	type R, S, B, W3, W5	± 2 K / 10 K _{Tamb}		
connection leads	effect	± 0.5 μV / 10 Ω		
	max. permissible resistance	250 Ω		
signalling of sensor error		configurable		
mV-sensor				
measuring deviation per	DIN IEC 770, 23 °C ± 5 K	± 10 μV or ³⁾ ± 0.05 % FS in mV		
temperature coefficient T_C		± (0.05 % FS + 0.02) mV / 10 K _{Tamb}		
connection leads	effect	± 0.5 μV / 10 Ω		
	max. permissible resistance	250 Ω		
Analogue output for measuring range		configurable: 4 ... 20 mA or 20 ... 4 mA, 2 wire design		
with type of sensor	RTDs	linear to temperature per DIN IEC 751 / JIS C 1606 / DIN 43 760:1987-09		
with type of sensor	thermocouple	linear to temperature per DIN IEC 584 / DIN 43 710:1985-12 / ASTM E988		
by simulation mode		independent from input signal, simulation value configurable from 3.5 mA up to 23 mA		
output limits configurable				
application specification		configurable from 3.6 mA up to 21.5 mA		
NAMUR NE 43		lower limit: 3.8 mA upper limit: 20.5 mA		
not active		lower limit: 3.6 mA upper limit: 21.5 mA		
load R_A		$R_A \leq (U_B - 9V) / 0.023A$ with R_A in Ω and U_B in V		
load effect		± 0.01 % of measuring span / 100 Ω		
measuring deviation per	DIN IEC 770, 23 °C ± 5 K	± 0.05 % of measuring span		
temperature coefficient T_C		± 0.1 % of measuring span / 10 K _{Tamb}		
damping		configurable: minimal 0.5 s , 1 s up to 60 s		
measured value update		approx. 2 / s		
power supply effect		± 0.005 % of measuring span / V		
Total measuring deviation		sum of input + output per DIN IEC 770, 23 °C ± 5 K		
Signalling at analogue output		with sensor error and internal malfunction		
NAMUR NE 43	up scale	> 21.0 mA		
	down scale	< 3.6 mA		
substitute value		configurable from 3.5 mA up to 23.0 mA		

1) beginning of measuring range maximum 50 % of end of measuring range
 2) technical data valid only for configured measuring range ≥ 400 °C
 3) whichever is greater
 4) valid only for configured measuring range with beginning ≥ -150 °C

FS full scale value of configured measuring range
 R_A load
 T_{amb} ambient temperature
 T_C temperature coefficient
 U_B loop power supply voltage, see power supply

Power supply U_B	
model T12.10.000 (without Ex-protection)	DC 9 ... 36 V
models T12.10.002 , T12.10.004 (with Ex-protection)	DC 9 ... 30 V
input power supply protection	reverse polarity
Ex-protection	EC Type Test DMT 98 ATEX E 008 X
model T12.10.002	II 1G EEx ia IIB / IIC T4 / T5 / T6
model T12.10.004	II 2G EEx ib IIB / IIC T4 / T5 / T6
permissible ambient temperature	-40 °C ... +85 °C with T4 -40 °C ... +75 °C with T5 -40 °C ... +60 °C with T6
maximum values for connection of the current loop circuit (connections + and -)	$U_i = 30$ V $I_i = 100$ mA $P_i = 705$ mW $L_i = 0.65$ mH $C_i = 25$ nF
maximum values for connection of the sensor circuit (connections 1 up to 4)	$U_o = 11.5$ V $I_o = 31$ mA $P_o = 87$ mW $L_i = 0.65$ mH $C_i = 125$ nF Group II B: $C_o = 11$ μ F $L_o = 8.6$ mH Group II C: $C_o = 1.5$ μ F $L_o = 8.6$ mH
Electromagnetic compatibility (EMC)	CE- Conformity per DIN EN 50081-1 (March 93) and DIN EN 50082-2 (February 96)
Special features	
isolation voltage (input versus analogue output)	1500 VAC, 60 s
ambient and storage temperature	
standard range	-40 ... +85 °C
option ¹⁾ : increased range	min. -50 °C max. +105 °C
climate application class	GPA DIN 40040
humidity	100 % relative humidity (unlimited with isolated sensor connection wires), moisture condensation permissible DIN IEC 68-2-30 Var. 2
vibration	10 ... 2000 Hz 5 g DIN IEC 68-2-6
shock	DIN IEC 68-2-27 $g_N = 30$
salt fog	DIN IEC 68-2-11
configuration and calibration data	permanently stored in EEPROM
testing current to monitor sensor	nom. 33 μ A during testing cycle, otherwise 0 μ A
self-monitoring	automatic execution of initial test after connection to power supply, thereafter monitoring due to internal malfunction
warm-up time	approx. 5 Min.
power consumption with U_B 24 V	max. 552 mW
communication-interface	Programming Unit (part of the configuration-set available as an accessory)
guarantee	5 years for performance with standard range of ambient temperature, legal warranty with increased range of ambient temperature
Case	for head mounting
material	plastic
degree of protection	case IP 66 / IP 67 IEC 529 / EN 60529
terminal connections	IP 00 IEC 529 / EN 60529
cross section of terminal connections	max. 2.5 mm ² , screws captive
weight	approx. 70 g
dimensions	see drawings

1) only possible for model T12.10.00, i.e. without Ex-protection

Dimensions in mm

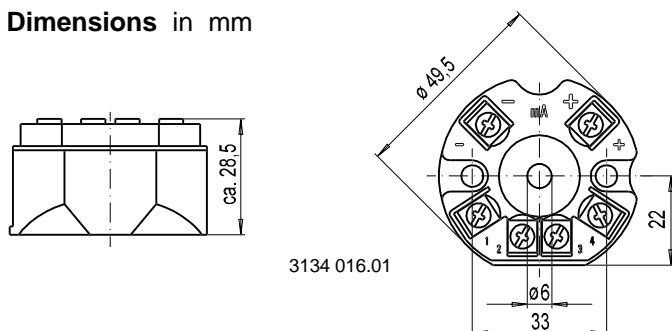

Load diagram

The permissible load is dependent upon the loop power supply voltage.

load R_A in Ω

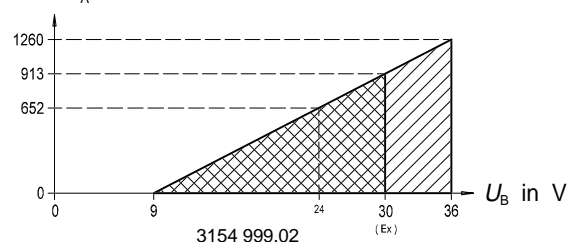

Accessory

Configuration-Set

The Configuration-Set contains

- Configuration Software (3,5" disk, Online Help)
- connection cable, RS 232-C (9-pin sub-D-plug)
- plug adapter (25-pin to 9-pin sub-D-plug)
- Programming Unit (Communication-Interface) incl. 9V battery
- two connection cables Programming Unit \leftrightarrow T12

Mounting material

- To use for mounting
- in the top of a connection head
- on a measuring insert, spring-loaded
- on a standard rail

Designation of terminal connectors

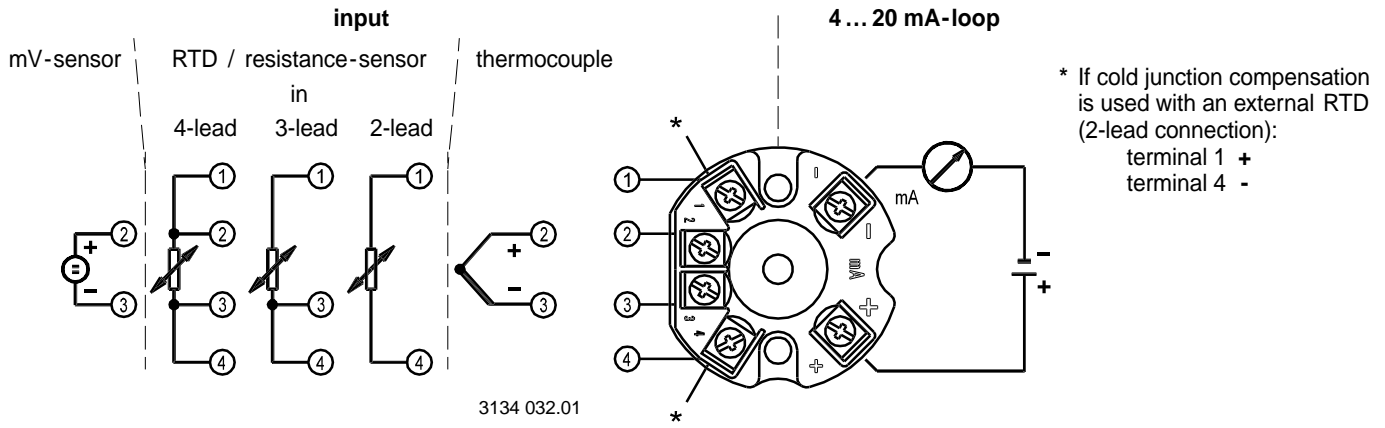

Connection of Programming Unit

* Yellow and green are connected only if configuration of the T12.10 is to be made when the transmitter is on-line.
When configuring in the workshop, an external power supply is not required as the Programming Unit provides the power.

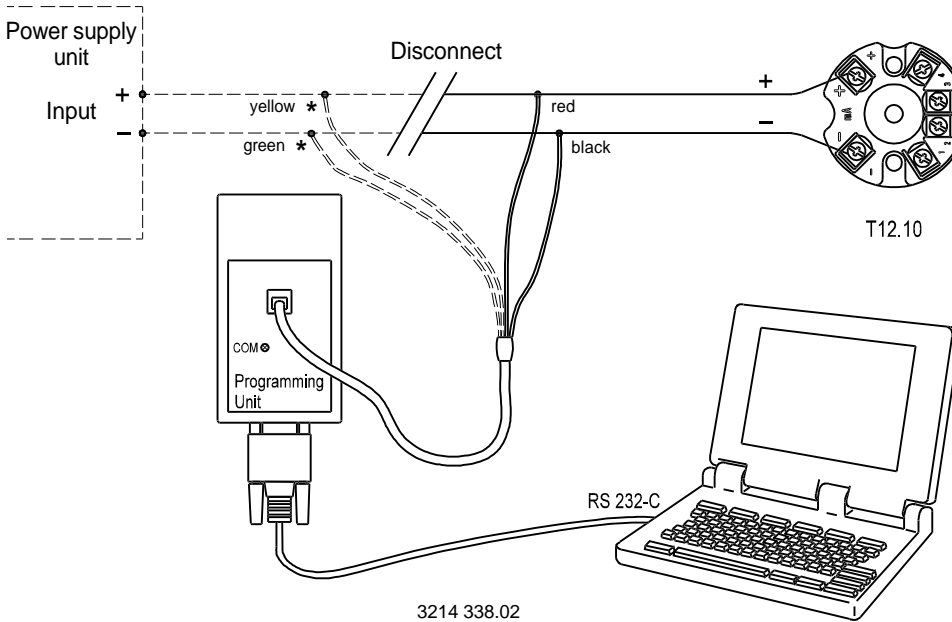

Ordering information

Order code per price list

Basic configuration: Input signal: Pt 100 in 3-lead connection, Measuring range: 0 ... 150 °C,
Output signal: 4 ... 20 mA, Output limits: NAMUR (lower limit: 3.8 mA upper limit: 20.5 mA),
Signalling of sensor error: NAMUR down scale (< 3.6 mA), Damping: 1 s, Mains: 50 Hz

Please use sheet "Help to Order" of the price list, when ordering temperature transmitter configured to customer specification.
Parameters which are not given will be set corresponding to the basic configuration.

Specifications and dimensions given in this leaflet are correct at the time of printing.
Modifications may take place and materials specified may be replaced by others without prior notice.



INGENIEROS ASOCIADOS DE CONTROL S.L.

Tel.: 913831390
comercial@ac-sl.es