

The Rock

Model SW100 Thermal Flow and Level Switch

- X All-welded 316SS or Hastelloy C-276 sensor
- X FM Approved explosion proof
- X CE approved
- X NEMA 4X wash-down proof
- X Single board, "no-connectors" design
- X 3000 psig (207 barg)
- X No moving parts
- X DPDT 5 amp relay
- X Single pot adjustment
- X Works on gases, liquids and slurries
- X 3A sanitary unit available
- X Clean and steam in place
- X $\pm 1\%$ of reading repeatability



PRODUCT DESCRIPTION

The ROCK flow and level switch was specifically designed for long-term reliable operation in the harshest industrial environments. Simply insert the SW100 in a line or vessel and adjust the single pot to the desired flow or level. Wetted parts are 316 stainless steel for durability and corrosion resistance. Hastelloy C-276 and other materials are available. The sensors utilize reference grade platinum RTD's resulting in excellent repeatability and rangeability. A 3A sanitary version is available.

THEORY OF OPERATION

The Model SW100 operates on the thermal principal of flow measurement. Its electronics provide a constant wattage to the sensor, heating it above the temperature of the fluid. Flow of the fluid causes removal of heat from the sensor, measured as a reduction in temperature. Therefore, the measure of mass flow velocity is the sensor's temperature above the fluid temperature.

The ROCK utilizes an advanced Mass-Balanced sensor which causes each sensing element to respond equally and indifferently to changes in temperature. This feature eliminates the "hunting" problem inherent in three-element, unbalanced thermal flow switches.

SPECIFICATIONS

Performance Specs

Repeatability:

± 1% of reading

Operating Specs

Liquid Range:

0.015 to 3 fps
(0.005 to 1 mps)

Gas Range:

1 to 100 sfps
(0.3 to 30 nmps)

Note: Extended ranges available or increase/decrease pipe section to bring flow within range.

Sensor:

Std -40 to 300°F (-40 to 150°C)
HT 32 to 482°F (0 to 250°C)
3000 psig (207 barg)

Enclosure:

-40 to 131°F (-40 to 55°C)

Response Time:

2 to 20 seconds
application dependent

Input Power:

24 VDC, ± 10%, 0.6 amp max.
115/230 VAC, ± 10%, 50/60 Hz,
25 watts max.

Relay Contacts:

2 form C (DPDT) 5 amp,
250 VAC resistive

Physical Specs

Materials:

Sensor: 316 SS, Hastelloy C-276,
others available

Sanitary unit body: 316 SS

Switch point adjustment:

Field set with single pot; or
Factory set to specified flow velocity (optional)

Clean and steam in place

Enclosure:

Cast aluminum; NEMA 4X (IP65)
Factory Mutual approved Class I,
Division 1, Groups B, C & D (T2C).
Class II/III, Division 1, Groups E, F
& G(T2A).

CE approved.

Dimensional

Note: Dimensions in parenthesis are centimeters. For certified drawings consult factory.

Standard Switch

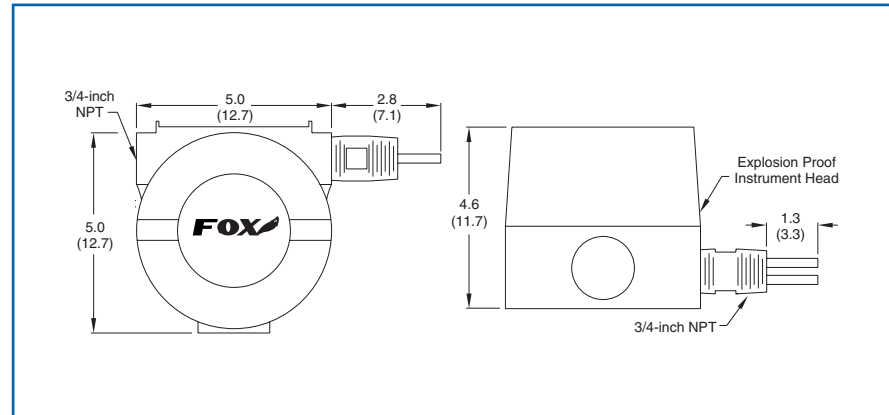

Extended Switch

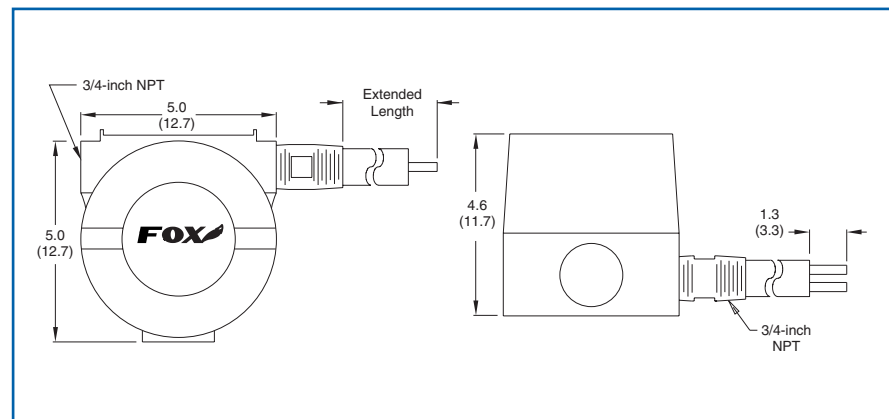

Sanitary Switch

