

DN 10 up to 50 mm; stainless steel



Advantages/Benefits

- ▶ **Modular program of ball valves**
- ▶ **Control heads with pilot valves and position feedback**
- ▶ **AS-Interface**
- ▶ **Pilot valves with NAMUR and Ex options**
- ▶ **Customized Fluid Control Systems with Burkert sensors and valves**

Design/Function

The ball valve family type 2651...56 is designed for any kind of application in the process industry. The ball valve consists of two variable modules, the valve body and the actuator.

Two body designs both in stainless steel are available as follows:

- The two-piece valve body is the economic solution in applications with low cycle rates and uncritical sealing conditions, slow and few changes of pressure and temperature of the fluid.
- The three-piece valve body for industrial applications is specifically equipped with a two level sealing system to get superior tightness in the stem area during temperature and pressure variations. Maintenance and changes of seals and seat can be done on line, while keeping the valve on the pipe.

The quarter turn for opening the valve can be done by a hand lever, by a pneumatic actuator or by a compact high performance electric actuator, which all can be used on the two-piece and on the three-piece valve body, depending on the application and on the kind of control of the process.

This modular concept allows to build up a ball valve for any degree of automation and any kind of application in the process industry.

A system can be completed with pilot valves for the operation of the pneumatic actuator, a compact position feedback, a Control HEAD, optional with AS-i bus, for ON/OFF control functions and an intelligent controller for position and process control.

An Easy LINK can be built up with any kind of sensor. The electric motor actuator has a standard signal input (4...20 mA) to be connected and controlled directly by a PLC.

Applications

Fluids

- Neutral gases and fluids
- Ultrapure water
- Slightly aggressive fluids
- Slightly contaminated liquids

Applications

- Water treatment / ozoning systems
- Slow processes / tank farming in beverage and pharmaceutical industry
- Shut-off armatures in chemical and dyeing industry
- Textile machines



INGENIEROS ASOCIADOS DE CONTROL S.L.
Telf.: 913031590
comercial@iac-siles

bürkert
Easy Fluid Control Systems

An optional variety of modules for your choice



Electric Actuator

Actuator sizes:

- 0: 10/12 Nm
- 1: 25 Nm
- 2: 100 Nm

Signals:

- On / Off
- 4 - 20 mA

Electric Position Feedback 1062

Versions:

- Mechanical limit switches
 - Silver contact
 - Gold contact
- Inductive limit switches
 - 2-wire
 - 3-wire
 - Namur EEx-i



Pneumatic Actuator T

Actuator sizes [mm]:

- E: ϕ 63
- G: ϕ 100

Actuator material:

- PA (Polyamide)

Control functions:

- I: double acting
- A: normally closed by spring (only size G)

Modules to be
ball valve system for
Pre-assembly
easy to integrate into



Hand Levers

Versions:

- 2-piece valve
 - SS 1.4301 with vinyl handle sleeve and locking device



Valve Bodies

Body configurations (ISO):

- 2-piece valve body
- 3-piece valve body

Valve sizes [mm]:

- 10.0 2- and 3 piece
- 12.0 2- and 3 piece
- 15.0 2- and 3 piece
- 20.0 2- and 3 piece
- 25.0 2- and 3 piece
- 32.0 2- and 3 piece
- 40.0 2- and 3 piece
- 50.0 only 2-piece valve

Type 2050



Pilot Valve Type 6519 Namur

Functions:

- 3/2 way
- 5/2 way

Materials:

- Brass
- Stainless Steel



TOP Control

Version:

- ON/OFF Control HEAD



combined to a
the process industry.
led system,
production facilities.



Connections:

- G (reduced and full)
- NPT (reduced and full)
- Rc (reduced and full)
- Butt weld on request
- Socket weld on request

Materials:

- Body: Stainless Steel (A351)
- Gasket: PTFE



Hand Levers

Versions:

- 3-piece valve
 - Cast SS 1.4301 with air cushioned vinyl handle sleeve and locking device

Technical data (valve bodies)

2-piece body version

- robust and economic
- blow-out proof stem design
- less changes of temperature and pressure
- low cycling rates

3-piece body version

- rugged industrial design
- control section "swing away" and seats to be changed, while keeping the valve on the pipe
- bottom entry stem prevents blow-out
- self-adjusting floating ball
- encapsulated body gasket seals off any possible leak path

Operating data (valve bodies)

Pressure range		Sealing	PTFE
2-piece version	0 up to 100 bar	Fluids	Neutral gases and fluids Ultrapure water Slightly aggressive fluids Contaminated liquids
3-piece version	0 up to 64 bar	Viscosity	max. 40 mm ² /s
Port connections	G 1/4 - G 2 1/4 NPT - 2 NPT Rc 1/4 - Rc 2	Medium temperature	-10° up to +120°C (>120°C on request)
Orifice		Max. ambient temperature	-10° up to +60°C
2-piece version	DN 10 - DN 50		
3-piece version	DN 10 - DN 40		

Materials (valve bodies)

2-piece body version

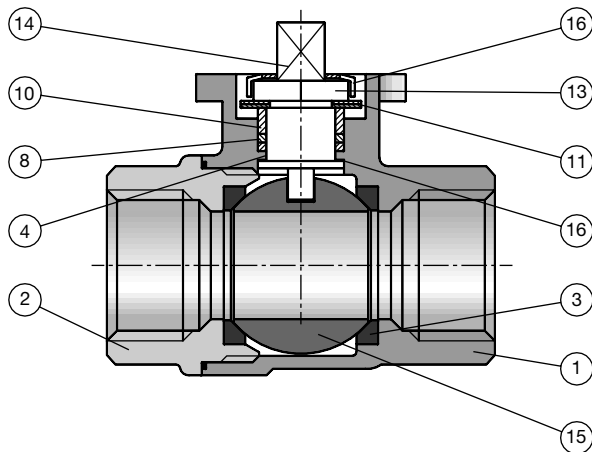

3-piece body version

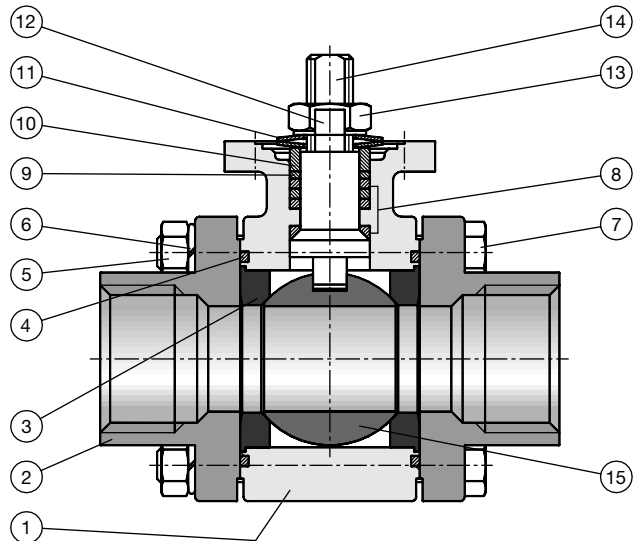

	DIN specification	ASTM/SUS specification
1. Body	SS 1.4401	ASTM A351 Grade CF8M
2. End cap	SS 1.4401	ASTM A351 Grade CF8M
3. Seat	RPTFE	RPTFE
4. Body gasket	PTFE / RPTFE	PTFE / RPTFE
5. Nut	SS 1.4301	SUS304
6. Washer	SS 1.4301	SUS304
7. Bolt	SS 1.4301	SUS304
8. Packing Set	PTFE	PTFE

	DIN specification	ASTM/SUS specification
9. Bushing	PTFE + graphite	PTFE + graphite
10. Gland	SS 1.4301	SUS304
11. Belleville washer	SS 1.4310	SUS301
12. Lock saddle	SS 1.4301	SUS304
13. Stem nut	SS 1.4301	SUS304
14. Stem	SS 1.4401	SUS316
15. Ball	SS 1.4401	SUS316
16. Thrust washer	PTFE	PTFE

Dimensions [mm] (valve bodies)

2-piece body version

This face must be free from burrs and sharp edges

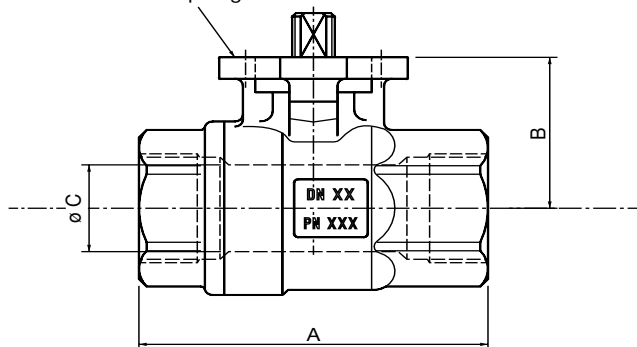

3-piece body version

This face must be free from burrs and sharp edges

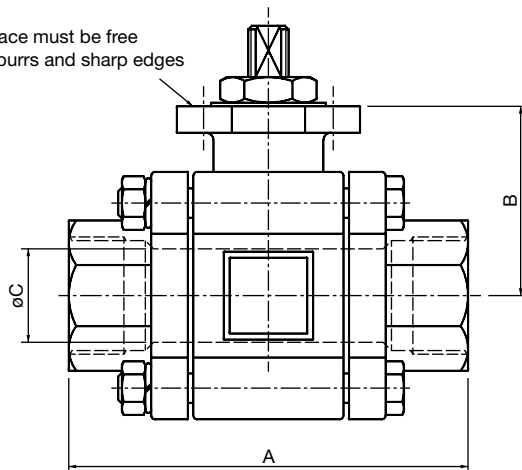

Port connection [inch]	Flange ISO 5211	Dimensions [mm]		
		A	B	ø C
G 1/4	F03	50.0	34.0	11.6
G 3/8	F03 / F04	60.0	34.0	12.7
G 1/2	F03 / F04	75.0	35.5	15.0
G 3/4	F04 / F05	80.0	39.0	20.0
G 1	F04 / F05	90.0	45.0	25.0
G 1 1/4	F04 / F05	110.0	50.0	31.8
G 1 1/2	F04 / F05	120.0	56.0	38.0
G 2	F05	140.0	67.5	50.8

Port conn. [inch]		Flange ISO 5211	Dimensions [mm]		
full bore	reduced bore		A	B	ø C
G 1/4	-	F03	66.6	27.7	10.0
G 3/8	G 1/2	F03	66.6	27.7	12.7
G 1/2	G 3/4	F04	71.6	38.2	15.0
G 3/4	G 1	F04	96.6	41.6	20.0
G 1	G 1 1/4	F05	109.0	51.6	25.0
G 1 1/4	G 1 1/2	F05	117.0	55.0	31.8
G 1 1/2	G 2	F07	129.0	66.0	38.1

Flange drilling according DIN 3337 / ISO 5211

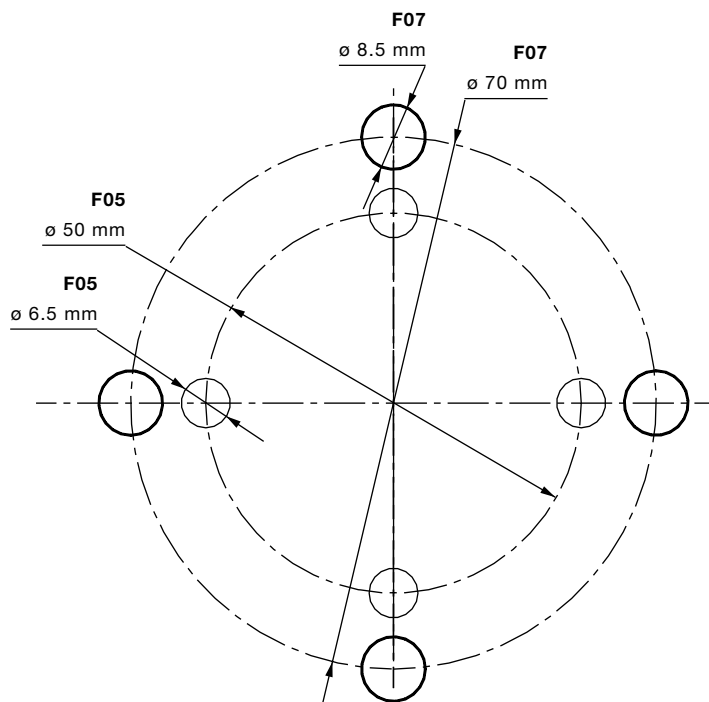
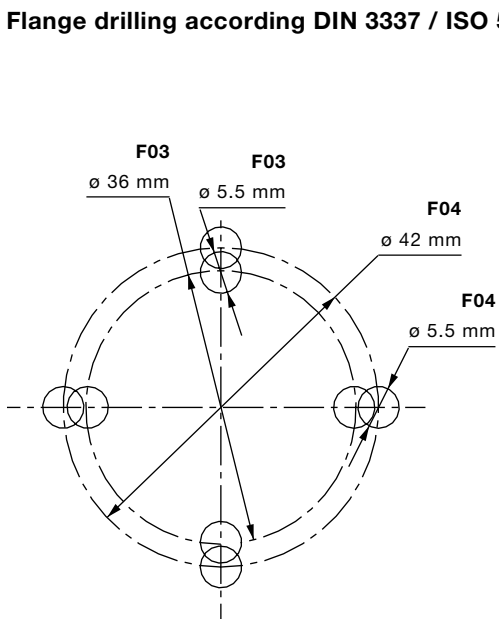

Materials (actuator - manual operation)

Handles for 2- and 3-piece ball valve

- SS304 with vinyl plastic cover

Dimensions [mm] (actuator - manual operation)

2-piece body version type 2651

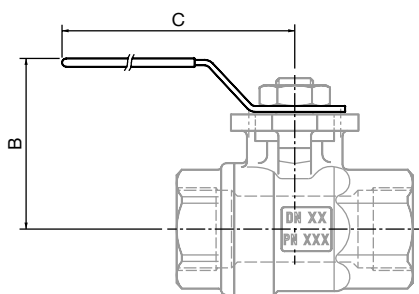

Orifice DN [mm]	Dimensions [mm]	
	B	C
10.0	50.0	96.0
12.0	53.0	96.0
15.0	53.0	96.0
20.0	64.0	125.0
25.0	66.0	125.0
32.0	79.0	170.0
40.0	83.0	170.0
50.0	94.0	190.0

3-piece body version type 2654

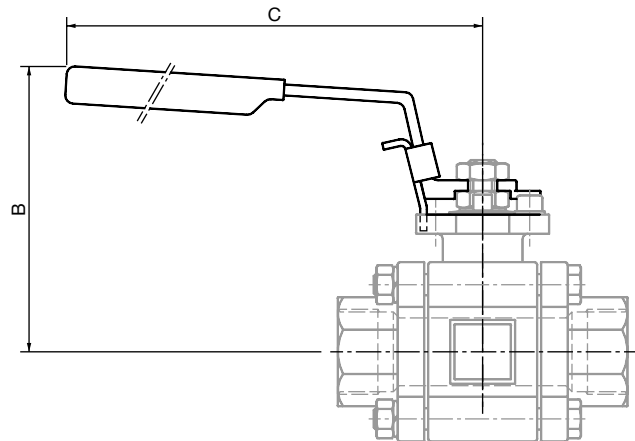

Orifice DN [mm]	Dimensions [mm]	
	B	C
10.0	63.5	115.0
12.0	63.5	115.0
15.0	82.0	130.0
20.0	86.0	130.0
25.0	98.0	165.0
32.0	100.0	165.0
40.0	116.0	200.0

Specifications / Ordering chart (actuator - manual operation)

Orifice DN	Port connection	Pressure range	Kv-value		Weight		Item No.	
			Full bore	Reduced bore	Full bore	Reduced bore	Full bore	Reduced bore
[mm]	[inch]	[bar]	[m ³ /h]		[kg]			

2-piece ball valve type 2651

10.0	G 1/4	0 - 100	7.0	–	0.60	–	432 045 K	–
12.0	G 3/8	0 - 100	9.0	–	0.75	–	432 046 L	–
15.0	G 1/2	0 - 100	11.0	–	0.85	–	432 047 M	–
20.0	G 3/4	0 - 100	26.0	–	1.45	–	432 048 W	–
25.0	G 1	0 - 100	39.0	–	2.00	–	432 049 X	–
32.0	G 1 1/4	0 - 100	69.0	–	2.75	–	432 050 U	–
40.0	G 1 1/2	0 - 100	103.0	–	4.10	–	432 051 R	–
50.0	G 2	0 - 100	200.0	–	5.50	–	432 052 J	–

3-piece ball valve type 2654

10.0	G 1/4	0 - 64	7.0	–	0.60	–	432 032 E	–
12.0	G 3/8	0 - 64	7.0	–	0.60	–	432 033 F	–
12.0	G 1/2	0 - 64	–	7.0	–	0.60	–	432 039 M
15.0	G 1/2	0 - 64	10.0	–	0.85	–	432 034 G	–
15.0	G 3/4	0 - 64	–	10.0	–	0.85	–	432 040 S
20.0	G 3/4	0 - 64	28.0	–	1.45	–	432 035 H	–
20.0	G 1	0 - 64	–	28.0	–	1.45	–	432 041 P
25.0	G 1	0 - 64	40.0	–	2.00	–	432 036 A	–
25.0	G 1 1/4	0 - 64	–	40.0	–	2.00	–	432 042 Q
32.0	G 1 1/4	0 - 64	71.0	–	2.75	–	432 037 B	–
32.0	G 1 1/2	0 - 64	–	71.0	–	2.75	–	432 043 R
40.0	G 1 1/2	0 - 64	103.0	–	4.10	–	432 038 L	–
40.0	G 2	0 - 64	–	103.0	–	4.10	–	432 044 J

Operating data (actuator - pneumatic operation)



Control function of actuator

A: single acting

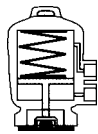

with spring force closed

I: double acting

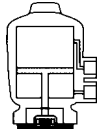

no spring

Size	<ul style="list-style-type: none"> • \varnothing 63 mm • \varnothing 100 mm
Control medium	Neutral gases and air
Control pressure (of actuator alone)	size \varnothing 63 mm 2 up to 10 bar size \varnothing 100 mm 2 up to 6 bar
Rotation	$90^\circ \pm 3^\circ$
Ambient temp.	-10° up to $+60^\circ\text{C}$
Response time	1 up to 3.5 s
Flange interface for assembly 5211	Flange F04, F05 and F07 acc. to DIN 3337 and ISO

Materials (actuator - pneumatic operation)

Flange	PA6 GF30 (Polyamid, glass-fiber reinforced)
Internal parts	POM and PBT
Rotary shaft	Stainless Steel 1.4308
Seals	NBR
Service ports	Stainless Steel 1.4305

Torque of actuator alone

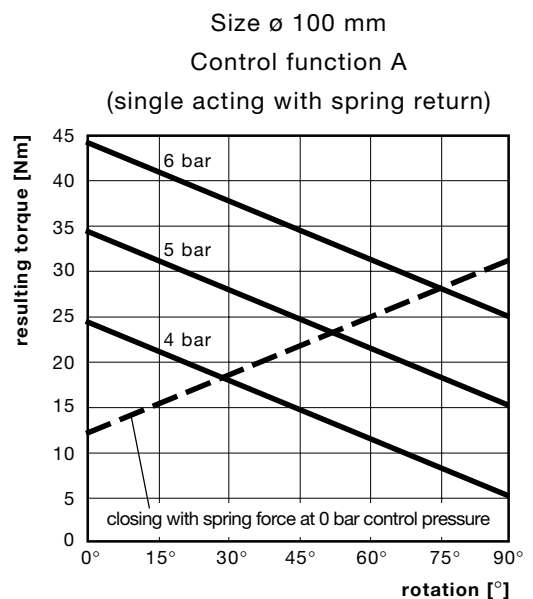
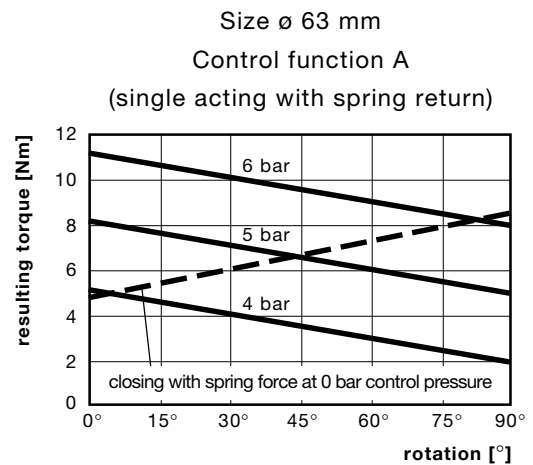
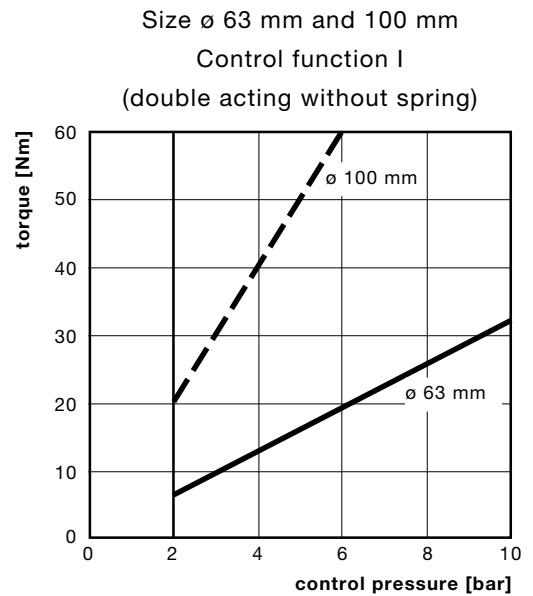

Dimensions [mm] (actuator - pneumatic operation)

2-piece body version type 2652

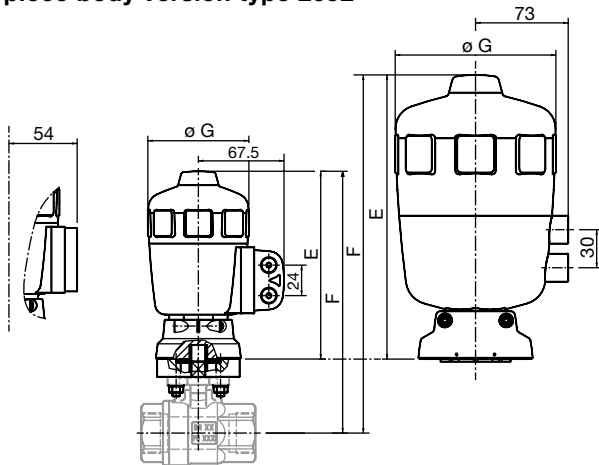

3-piece body version type 2655

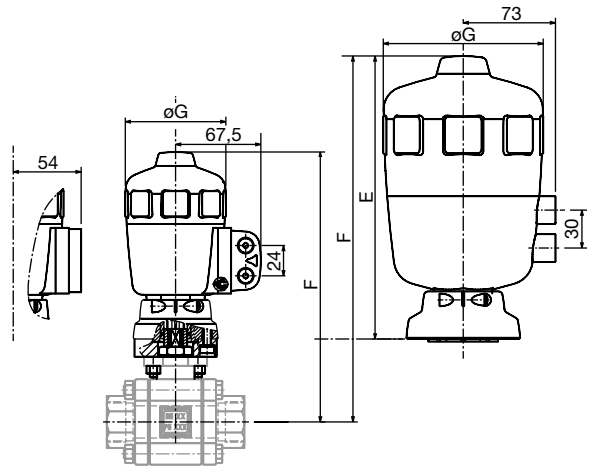

Orifice DN	Port connection	Actuator	Dimensions [mm]		
			E	F	G
[mm]	[inch]				
10.0	G 1/4	E (63)	148.0	196.0	80.0
12.0	G 3/8	E (63)	148.0	196.0	80.0
15.0	G 1/2	E (63)	148.0	197.5	80.0
15.0	G 1/2	E (63)	224.0	271.0	127.0
20.0	G 3/4	E (63)	148.0	201.0	80.0
20.0	G 3/4	G (100)	224.0	271.0	127.0
25.0	G 1	E (63)	148.0	207.0	80.0
25.0	G 1	G (100)	224.0	280.0	127.0
32.0	G 1 1/4	G (100)	224.0	288.0	127.0
40.0	G 1 1/2	G (100)	224.0	294.0	127.0
50.0	G 2	G (100)	224.0	296.5	127.0

Orifice DN	Port connection		Actuator	Dimensions [mm]		
	Full bore	Reduced bore		E	F	G
[mm]	[inch]	[inch]				
10.0	G 1/4	-	E (63)	148.0	190.0	80.0
12.0	G 3/8	G 1/2	E (63)	148.0	190.0	80.0
15.0	G 1/2	G 3/4	E (63)	148.0	200.0	80.0
15.0	G 1/2	G 3/4	G (100)	224.0	273.0	127.0
20.0	G 3/4	G 1	E (63)	148.0	204.0	80.0
20.0	G 3/4	G 1	G (100)	224.0	277.0	127.0
25.0	G 1	G 1 1/4	E (63)	148.0	214.0	80.0
25.0	G 1	G 1 1/4	G (100)	224.0	287.0	127.0
32.0	G 1 1/4	G 1 1/2	G (100)	224.0	293.0	127.0
40.0	G 1 1/2	G 2	G (100)	224.0	304.0	127.0

6519 Namur pilot valves for powered actuator



Type 6519 Namur with cable plug type 2508, form A
DN 6; PN 2-8 bar



Type 6519 Namur Ex with terminal box
DN 6; PN 2-8 bar



Type 6519 Namur Ex with moulded-in cable
DN 6; PN 2-8 bar

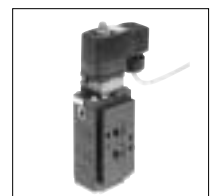

Specifications / Ordering chart (actuator - pneumatic operation)

Control function	Orifice DN [mm]	Port connection [inch]	Actuator size [ø mm]	Pressure range [bar]	Control pressure min / max [bar]	Kv-value		Weight		Item No.	
						Full bore [m³/h]	Reduced bore	Full bore [kg]	Reduced bore	Full bore	Reduced bore

2-piece ball valve type 2652

A	10.0	G 1/4	63.0	0 - 64	4 / 10	7.0	-	3.90	-	435 172 J	-
A	12.0	G 3/8	63.0	0 - 64	4 / 10	9.0	-	3.90	-	435 173 K	-
A	15.0	G 1/2	63.0	0 - 40	4 / 10	11.0	-	3.90	-	435 174 L	-
A	15.0	G 1/2	100.0	0 - 64	4 / 6	11.0	-	4.10	-	431 108 X	-
A	20.0	G 3/4	100.0	0 - 64	4 / 6	26.0	-	4.80	-	431 109 Y	-
A	25.0	G 1	100.0	0 - 64	4 / 6	39.0	-	5.30	-	431 110 L	-
I	10.0	G 1/4	63.0	0 - 64	4 / 10	7.0	-	1.60	-	429 203 C	-
I	12.0	G 3/8	63.0	0 - 64	4 / 10	9.0	-	1.70	-	429 204 D	-
I	15.0	G 1/2	63.0	0 - 40	4 / 10	11.0	-	1.80	-	429 205 E	-
I	15.0	G 1/2	100.0	0 - 64	4 / 6	11.0	-	3.50	-	444 244 B	-
I	20.0	G 3/4	63.0	0 - 40	4 / 10	26.0	-	2.40	-	429 206 F	-
I	20.0	G 3/4	100.0	0 - 64	4 / 6	26.0	-	4.20	-	444 245 C	-
I	25.0	G 1	63.0	0 - 40	4 / 10	39.0	-	3.00	-	429 207 G	-
I	25.0	G 1	100.0	0 - 64	4 / 6	39.0	-	4.70	-	444 246 D	-
I	32.0	G 1 1/4	100.0	0 - 64	4 / 6	69.0	-	5.30	-	429 208 R	-
I	40.0	G 1 1/2	100.0	0 - 40	4 / 6	103.0	-	6.60	-	429 209 J	-
I	50.0	G 2	100.0	0 - 40	4 / 6	200.0	-	8.00	-	429 210 E	-

3-piece ball valve type 2655

A	10.0	G 1/4	63.0	0 - 64	4 / 10	7.0	-	4.00	-	435 175 M	-
A	12.0	G 3/8	63.0	0 - 64	4 / 10	7.0	-	4.00	-	435 176 N	-
A	12.0	G 1/2	63.0	0 - 64	4 / 10	-	7.0	-	4.00	-	435 178 Y
A	15.0	G 1/2	63.0	0 - 40	4 / 10	10.0	-	4.00	-	435 177 P	-
A	15.0	G 1/2	100.0	0 - 64	4 / 6	10.0	-	4.20	-	431 204 X	-
A	15.0	G 3/4	63.0	0 - 40	4 / 10	-	10.0	-	4.00	-	435 179 Z
A	15.0	G 3/4	100.0	0 - 64	4 / 6	-	10.0	-	4.20	-	431 214 Q
A	20.0	G 3/4	100.0	0 - 64	4 / 6	28.0	-	4.80	-	431 205 Y	-
A	20.0	G 1	100.0	0 - 64	4 / 6	-	28.0	-	4.80	-	431 215 R
A	25.0	G 1	100.0	0 - 64	4 / 6	40.0	-	5.35	-	431 206 Z	-
A	25.0	G 1 1/4	100.0	0 - 64	4 / 6	-	40.0	-	5.35	-	431 216 J
I	10.0	G 1/4	63.0	0 - 64	4 / 10	7.0	-	1.60	-	431 195 E	-
I	12.0	G 3/4	63.0	0 - 64	4 / 10	7.0	-	1.60	-	431 196 F	-
I	12.0	G 1/2	63.0	0 - 64	4 / 10	-	7.0	-	1.60	-	431 207 S
I	15.0	G 1/2	63.0	0 - 40	4 / 10	10.0	-	1.60	-	431 197 G	-
I	15.0	G 1/2	100.0	0 - 64	4 / 6	10.0	-	3.10	-	444 247 E	-
I	15.0	G 3/4	63.0	0 - 40	4 / 10	-	10.0	-	1.60	-	431 208 B
I	15.0	G 3/4	100.0	0 - 64	4 / 6	-	10.0	-	3.10	-	444 248 P
I	20.0	G 3/4	63.0	0 - 40	4 / 10	28.0	-	2.20	-	431 198 R	-
I	20.0	G 3/4	100.0	0 - 64	4 / 6	28.0	-	3.30	-	444 249 Q	-
I	20.0	G 1	63.0	0 - 40	4 / 10	-	28.0	-	2.20	-	431 209 C
I	20.0	G 1	100.0	0 - 64	4 / 6	-	28.0	-	3.30	-	444 250 M
I	25.0	G 1	63.0	0 - 40	4 / 10	40.0	-	2.80	-	431 199 J	-
I	25.0	G 1	100.0	0 - 64	4 / 6	40.0	-	3.90	-	444 251 A	-
I	25.0	G 1 1/4	63.0	0 - 64	4 / 10	-	40.0	-	2.80	-	431 210 Y
I	25.0	G 1 1/4	100.0	0 - 64	4 / 6	-	40.0	-	3.90	-	444 252 B
I	32.0	G 1 1/4	100.0	0 - 64	4 / 6	71.0	-	5.10	-	431 200 F	-
I	32.0	G 1 1/2	100.0	0 - 64	4 / 6	-	71.0	-	5.10	-	431 211 M
I	40.0	G 1 1/2	100.0	0 - 40	4 / 6	103.0	-	6.70	-	431 201 U	-
I	40.0	G 2	100.0	0 - 40	4 / 6	-	103.0	-	6.70	-	431 212 N

Specifications / Ordering chart (actuator - pneumatic operation)

5/2 / 3/2 way, DN 6, G 1/4, PN 2 - 8 bar, PA body:

Type 6519 Namur with standard cable plug type 2508

Material port connection	Ex approval	Item No. Voltage			
		24/DC	24/50-60	110/50-60	230/50-60
MS (nickel-plated)	-	131 421 B	131 422 C	131 423 D	131 424 E
SS	-	131 425 F	131 426 G	131 427 H	131 428 J

Type 6519 Namur Ex with moulded-in cable

Material port connection	Ex-approval	Item No. Voltage			
		024/UC	110/UC	230/UC	-
MS (nickel-plated)	EEx-m-II T5	131 627 R	131 628 S	131 629 T	-
SS	EEx-m-II T5	131 631 M	131 632 N	131 633 P	-
MS (nickel-plated)	EEx-m-II T6	425 725 J	426 026 A	426 027 B	-
SS	EEx-m-II T6	431 442 M	431 443 N	431 444 P	-

Adapter plate for NAMUR pilot valve:

Description	Material	Item No.
for actuator ø 63 mm	PA	427 405 M
for actuator ø 100 mm	Brass	637 114 J
for actuator ø 100 mm	SS	634 275 G

For other versions, please see data sheets 6519 Namur and 6519 Namur Ex

Optional system modules

Electrical position feedback type 1062



Positions are electrically signaled (open, closed and open & closed) with following features:

- LEDs provide optical position indication
- Mechanic switches with gold/silver contacts
- Inductive switches in 2- and 3-wire (PNP / NPN) technology
- Inductive switches acc. to DIN 19234 (Namur EEx-i)

 [Data sheet type 1062](#)

Pilot solenoid valve type 6519 Namur



Pneumatic pilot valve for the actuation:

- 3/2 and 5/2 way direct mounted
- Namur flange
- PN 2 up to 8 bar
- Flow rate 900 l/min
- EEx-m-II C T5 version

 [Data sheet type 6519 Namur and type 6519 Namur Ex](#)

TOP Control type 8631 (ON/OFF)



TOP Control type 8631 for pneumatic piloting and electronic control of the pneumatic actuated ball valve:

- Single / double acting
- PG / EaseOn / PG-AS-i / Multipole-ASI connections
- G / NPT / Rc threaded supply ports
- EEx-ia version accord. to ATEX

 [Data sheet 265X with TopControl](#)



Sensors



For flow, level, analysis, pressure and temperature

- Sensor - only with frequency / PT100 signal
- Transmitter
- Switch
- Batch



 [Data sheets type 80XX, 81XX, 82XX, 83XX, 84XX, SLXX, STXX](#)



Technical data (actuator - electric operation)

Power failure Valve open with two limit switches

Operating data (actuator - electric operation)

Actuator type	Operating voltage with tolerance $\pm 10\%$ [V]	Power required [W]	Torque [Nm]	Duty cycles [%]	Full rotation time [s/90°]	with / without Input signal [mA]
3011	24 DC	7	12	100	10	4...20
	230/50 AC	12	10	70	10	4...20
3001	24 DC	20	25	100	7	4...20
	110/50 AC	55	25	50	7	-
	230/50 AC	55	25	50	7	4...20
3002	24 DC	20	100	100	14	4...20
	110/50 AC	55	100	50	14	-
	230/50 AC	55	100	50	14	4...20

Rotation	$90^\circ \pm 3^\circ$
Ambient temp.	-10° up to +50°C
Limit switch	Changeover switch, single-pole
Electrical connection	Cable plug for cable $\varnothing 6 - 7$ mm acc. to DIN 43650 A
Rating	IP65
Signals	
Control signal	4...20 mA
Impedance signal input	R input: < 50 Ω
Accuracy	Linearity: < $\pm 1,5\%$ Hysteresis: < $\pm 1,5\%$
Flange interface	F05 acc. to ISO 5211
Installation	as required, preferably with solenoid system upright

Materials (actuator - electric operation)

Housing: Polycarbonate

Options (actuator - electric operation)

For motors 3001 / 3002 with 110/50 and 230/50:

- Drive torque limiter
- Safety positions - closing at power breakdown
- opening at power breakdown

For all motors:

- Electrical feed back signal
- Electronic control of drive torque
- Standard signal 0 – 10 V

Dimensions [mm] (actuator - pneumatic operation)

2-piece body version type 2653

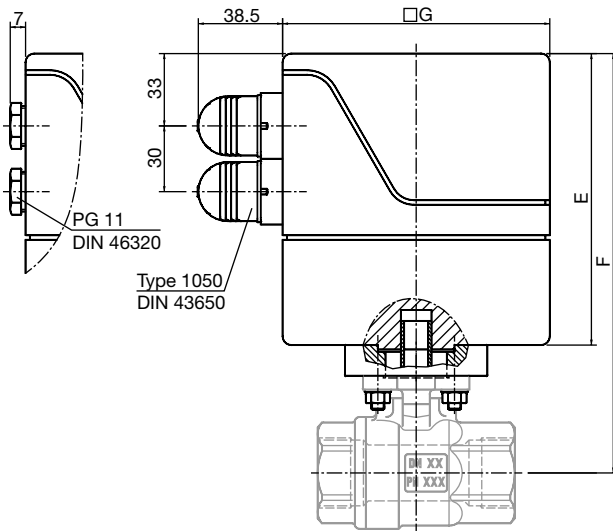

3-piece body version type 2656

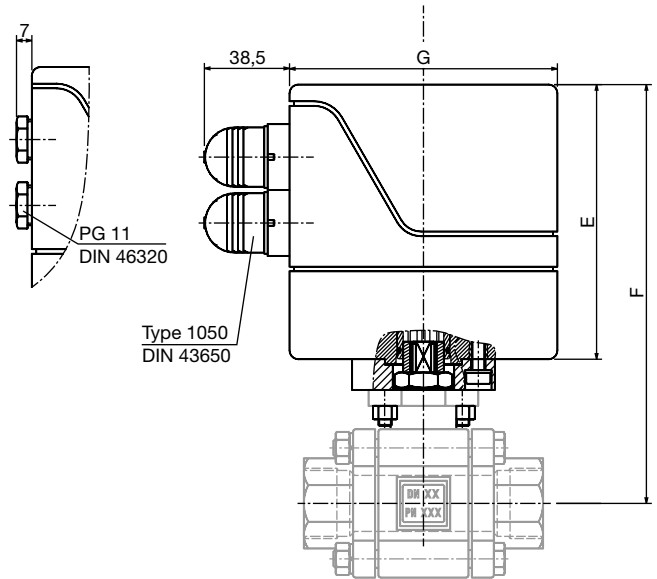

Orifice DN	Port connection	Actuator	Dimensions [mm]		
			E	F	G
[mm]	[inch]				
10.0	G 1/4	3011	125.0	173.0	122.0
10.0	G 1/4	3001	135.0	183.0	122.0
12.0	G 3/8	3011	125.0	173.0	122.0
12.0	G 3/8	3001	135.0	183.0	122.0
15.0	G 1/2	3011	125.0	174.5	122.0
15.0	G 1/2	3001	135.0	184.5	122.0
20.0	G 3/4	3011	125.0	178.0	122.0
20.0	G 3/4	3001	135.0	188.0	122.0
25.0	G 1	3001	135.0	194.0	122.0
25.0	G 1	3002	170.0	229.0	122.0
32.0	G 1 1/4	3001	135.0	199.0	122.0
32.0	G 1 1/4	3002	170.0	234.0	122.0
40.0	G 1 1/2	3002	170.0	240.0	122.0
50.0	G 2	3002	170.0	242.5	122.0

Orifice DN	Port connection		Actuator	Dimensions [mm]				
	Full bore	Reduced bore		E	E*	F	F*	G
[mm]	[inch]	[inch]						
10.0	G 1/4	-	3011	125	125	167	167	122
10.0	G 1/4	-	3001	135	185	177	207	122
12.0	G 3/8	G 1/2	3011	125	125	167	167	122
12.0	G 3/8	G 1/2	3001	135	185	177	207	122
15.0	G 1/2	G 3/4	3011	125	125	178	178	122
15.0	G 1/2	G 3/4	3001	135	185	188	218	122
20.0	G 3/4	G 1	3011	125	125	181	181	122
20.0	G 3/4	G 1	3001	135	185	191	221	122
25.0	G 1	G 1 1/4	3001	135	185	201	251	122
25.0	G 1	G 1 1/4	3002	170	220	236	286	122
32.0	G 1 1/4	G 1 1/2	3001	135	185	204	254	122
32.0	G 1 1/4	G 1 1/2	3002	170	220	239	289	122
40.0	G 1 1/2	G 2	3002	170	220	215	265	122

E* and F* 4-20mA version

Optional system modules

Sensors



For flow, level, analysis, pressure and temperature

- Sensor - only with frequency / PT100 signal
- Transmitter
- Switch
- Batch

 Data sheets type 80XX, 81XX, 82XX, 83XX, 84XX

Specifications / Ordering chart (actuator - electric operation)

Orifice DN	Port conn.	Voltage		Actuator type	Pressure range	Kv-value		Weight		Item No.	
		without norm signal	with norm signal			Full bore	Reduced bore	Full bore	Reduced bore	Full bore	Reduced bore
[mm]	[inch]		4...20 mA		[bar]	[m³/h]		[kg]			

2-piece ball valve type 2653

10.0	G 1/4	24 V DC	-	3011	0 - 40 *	7.0	-	2.60	-	431 127 H	-
10.0	G 1/4	230 V 50 Hz	-	3011	0 - 40 *	7.0	-	2.60	-	429 211 T	-
10.0	G 1/4	-	24 V DC	3011	0 - 40 *	7.0	-	2.60	-	431 128 J	-
10.0	G 1/4	-	230 V 50 Hz	3011	0 - 40 *	7.0	-	2.60	-	431 129 K	-
12.0	G 3/8	24 V DC	-	3011	0 - 40 *	9.0	-	2.70	-	431 130 Q	-
12.0	G 3/8	230 V 50 Hz	-	3011	0 - 40 *	9.0	-	2.70	-	429 212 U	-
12.0	G 3/8	-	24 V DC	3011	0 - 40 *	9.0	-	2.70	-	431 131 D	-
12.0	G 3/8	-	230 V 50 Hz	3011	0 - 40 *	9.0	-	2.70	-	431 132 E	-
15.0	G 1/2	24 V DC	-	3011	0 - 40 *	11.0	-	2.80	-	431 133 F	-
15.0	G 1/2	230 V 50 Hz	-	3011	0 - 40 *	11.0	-	2.80	-	429 213 V	-
15.0	G 1/2	-	24 V DC	3011	0 - 40 *	11.0	-	2.80	-	431 134 G	-
15.0	G 1/2	-	230 V 50 Hz	3011	0 - 40 *	11.0	-	2.80	-	431 135 H	-
20.0	G 3/4	24 V DC	-	3001	0 - 64	26.0	-	5.30	-	444 253 C	-
20.0	G 3/4	230 V 50 Hz	-	3001	0 - 64	26.0	-	5.30	-	444 254 D	-
20.0	G 3/4	-	24 V DC	3001	0 - 64	26.0	-	5.30	-	444 255 E	-
20.0	G 3/4	-	230 V 50 Hz	3001	0 - 64	26.0	-	5.30	-	444 256 F	-
25.0	G 1	24 V DC	-	3001	0 - 40 *	39.0	-	5.90	-	431 139 M	-
25.0	G 1	110 V 50 Hz	-	3001	0 - 40 *	39.0	-	5.90	-	431 140 S	-
25.0	G 1	230 V 50 Hz	-	3001	0 - 40 *	39.0	-	5.90	-	429 215 X	-
25.0	G 1	-	24 V DC	3001	0 - 40 *	39.0	-	5.90	-	431 141 P	-
25.0	G 1	-	230 V 50 Hz	3001	0 - 40 *	39.0	-	5.90	-	431 142 Q	-
32.0	G 1 1/4	24 V DC	-	3001	0 - 40 *	69.0	-	6.70	-	431 143 R	-
32.0	G 1 1/4	110 V 50 Hz	-	3001	0 - 40 *	69.0	-	6.70	-	431 144 J	-
32.0	G 1 1/4	230 V 50 Hz	-	3001	0 - 40 *	69.0	-	6.70	-	429 216 Y	-
32.0	G 1 1/4	-	24 V DC	3001	0 - 40 *	69.0	-	6.70	-	431 145 K	-
32.0	G 1 1/4	-	230 V 50 Hz	3001	0 - 40 *	69.0	-	6.70	-	431 146 L	-
40.0	G 1 1/2	24 V DC	-	3002	0 - 64	103.0	-	8.40	-	431 147 M	-
40.0	G 1 1/2	110 V 50 Hz	-	3002	0 - 64	103.0	-	8.40	-	431 148 W	-
40.0	G 1 1/2	230 V 50 Hz	-	3002	0 - 64	103.0	-	8.40	-	429 217 Z	-
40.0	G 1 1/2	-	24 V DC	3002	0 - 64	103.0	-	8.40	-	431 149 X	-
40.0	G 1 1/2	-	230 V 50 Hz	3002	0 - 64	103.0	-	8.40	-	431 150 U	-
50.0	G 2	24 V DC	-	3002	0 - 64	200.0	-	9.80	-	431 151 R	-
50.0	G 2	110 V 50 Hz	-	3002	0 - 64	200.0	-	9.80	-	431 152 J	-
50.0	G 2	230 V 50 Hz	-	3002	0 - 64	200.0	-	9.80	-	429 218 A	-
50.0	G 2	-	24 V DC	3002	0 - 64	200.0	-	9.80	-	431 153 K	-
50.0	G 2	-	230 V 50 Hz	3002	0 - 64	200.0	-	9.80	-	431 154 L	-

* 64 bar versions on request

Specifications / Ordering chart (actuator - electric operation)

Orifice DN [mm]	Port conn. [inch]	Voltage		Actuator type	Pressure range [bar]	Kv-value		Weight		Item No.	
		without norm signal	with norm signal 4...20 mA			Full bore [m³/h]	Reduced bore	Full bore [kg]	Reduced bore	Full bore	Reduced bore

3-piece ball valve type 2656

10.0	G 1/4	24 V DC	-	3011	0 - 40 *	7.0	-	2.70	-	431 239 Z	-
10.0	G 1/4	230 V 50 Hz	-	3011	0 - 40 *	7.0	-	2.70	-	431 240 E	-
10.0	G 1/4	-	24 V DC	3011	0 - 40 *	7.0	-	2.70	-	431 241 T	-
10.0	G 1/4	-	230 V 50 Hz	3011	0 - 40 *	7.0	-	2.70	-	431 242 U	-
12.0	G 3/8	24 V DC	-	3011	0 - 40 *	7.0	-	2.70	-	431 243 V	-
12.0	G 1/2	24 V DC	-	3011	0 - 40 *	-	7.0	-	2.70	-	431 270 C
12.0	G 3/8	230 V 50 Hz	-	3011	0 - 40 *	7.0	-	2.70	-	431 244 W	-
12.0	G 1/2	230 V 50 Hz	-	3011	0 - 40 *	-	7.0	-	2.70	-	431 271 Z
12.0	G 3/8	-	24 V DC	3011	0 - 40 *	7.0	-	2.70	-	431 245 X	-
12.0	G 1/2	-	24 V DC	3011	0 - 40 *	-	7.0	-	2.70	-	431 272 S
12.0	G 3/8	-	230 V 50 Hz	3011	0 - 40 *	7.0	-	2.70	-	431 246 Y	-
12.0	G 1/2	-	230 V 50 Hz	3011	0 - 40 *	-	7.0	-	2.70	-	431 273 T
15.0	G 1/2	24 V DC	-	3011	0 - 40 *	10.0	-	2.90	-	431 247 Z	-
15.0	G 3/4	24 V DC	-	3011	0 - 40 *	-	10.0	-	2.90	-	431 274 U
15.0	G 1/2	230 V 50 Hz	-	3011	0 - 40 *	10.0	-	2.90	-	431 248 A	-
15.0	G 3/4	230 V 50 Hz	-	3011	0 - 40 *	-	10.0	-	2.90	-	431 275 V
15.0	G 1/2	-	24 V DC	3011	0 - 40 *	10.0	-	2.90	-	431 249 B	-
15.0	G 3/4	-	24 V DC	3011	0 - 40 *	-	10.0	-	2.90	-	431 276 W
15.0	G 1/2	-	230 V 50 Hz	3011	0 - 40 *	10.0	-	2.90	-	431 250 G	-
15.0	G 3/4	-	230 V 50 Hz	3001	0 - 64	-	10.0	-	2.90	-	431 277 X
20.0	G 3/4	24 V DC	-	3001	0 - 64	28.0	-	5.40	-	444 257 G	-
20.0	G 1	24 V DC	-	3001	0 - 64	-	28.0	-	5.40	-	444 258 R
20.0	G 3/4	230 V 50 Hz	-	3001	0 - 64	28.0	-	5.40	-	444 259 J	-
20.0	G 1	230 V 50 Hz	-	3001	0 - 64	-	28.0	-	5.40	-	444 260 P
20.0	G 3/4	-	24 V DC	3001	0 - 64	28.0	-	5.40	-	444 261 C	-
20.0	G 1	-	24 V DC	3001	0 - 64	-	28.0	-	5.40	-	444 262 D
20.0	G 3/4	-	230 V 50 Hz	3001	0 - 64	28.0	-	5.40	-	444 263 E	-
20.0	G 1	-	230 V 50 Hz	3001	0 - 64	-	28.0	-	5.40	-	444 264 F
25.0	G 1	24 V DC	-	3001	0 - 40 *	40.0	-	6.00	-	431 255 Z	-
25.0	G 1 1/4	24 V DC	-	3001	0 - 40 *	-	40.0	-	6.00	-	431 282 M
25.0	G 1	110 V 50 Hz	-	3001	0 - 40 *	40.0	-	6.00	-	431 256 S	-
25.0	G 1 1/4	110 V 50 Hz	-	3001	0 - 40 *	-	40.0	-	6.00	-	431 283 N
25.0	G 1	230 V 50 Hz	-	3001	0 - 40 *	40.0	-	6.00	-	431 257 T	-
25.0	G 1 1/4	230 V 50 Hz	-	3001	0 - 40 *	-	40.0	-	6.00	-	431 284 P
25.0	G 1	-	24 V DC	3001	0 - 40 *	40.0	-	6.00	-	431 258 C	-
25.0	G 1 1/4	-	24 V DC	3001	0 - 40 *	-	40.0	-	6.00	-	431 285 Q
25.0	G 1	-	230 V 50 Hz	3001	0 - 40 *	40.0	-	6.00	-	431 259 D	-
25.0	G 1 1/4	-	230 V 50 Hz	3001	0 - 40 *	-	40.0	-	6.00	-	431 286 R
32.0	G 1 1/4	24 V DC	-	3001	0 - 40 *	71.0	-	6.70	-	431 260 A	-
32.0	G 1 1/2	24 V DC	-	3001	0 - 40 *	-	71.0	-	6.70	-	431 287 J
32.0	G 1 1/4	110 V 50 Hz	-	3001	0 - 40 *	71.0	-	6.70	-	431 261 X	-
32.0	G 1 1/2	110 V 50 Hz	-	3001	0 - 40 *	-	71.0	-	6.70	-	431 288 T
32.0	G 1 1/4	230 V 50 Hz	-	3001	0 - 40 *	71.0	-	6.70	-	431 262 Y	-
32.0	G 1 1/2	230 V 50 Hz	-	3001	0 - 40 *	-	71.0	-	6.70	-	431 289 U
32.0	G 1 1/4	-	24 V DC	3001	0 - 40 *	71.0	-	6.70	-	431 263 Z	-
32.0	G 1 1/2	-	24 V DC	3001	0 - 40 *	-	71.0	-	6.70	-	431 290 Z
32.0	G 1 1/4	-	230 V 50 Hz	3001	0 - 40 *	71.0	-	6.70	-	431 264 S	-
32.0	G 1 1/2	-	230 V 50 Hz	3001	0 - 40 *	-	71.0	-	6.70	-	431 291 N
40.0	G 1 1/2	24 V DC	-	3002	0 - 64	103.0	-	8.50	-	431 265 T	-
40.0	G 2	24 V DC	-	3002	0 - 64	-	103.0	-	8.50	-	431 292 P
40.0	G 1 1/2	110 V 50 Hz	-	3002	0 - 64	103.0	-	8.50	-	431 266 U	-
40.0	G 2	110 V 50 Hz	-	3002	0 - 64	-	103.0	-	8.50	-	431 293 Q
40.0	G 1 1/2	230 V 50 Hz	-	3002	0 - 64	103.0	-	8.50	-	431 267 V	-
40.0	G 2	230 V 50 Hz	-	3002	0 - 64	-	103.0	-	8.50	-	431 294 R
40.0	G 1 1/2	-	24 V DC	3002	0 - 64	103.0	-	8.50	-	431 268 E	-
40.0	G 2	-	24 V DC	3002	0 - 64	-	103.0	-	8.50	-	431 295 J
40.0	G 1 1/2	-	230 V 50 Hz	3002	0 - 64	103.0	-	8.50	-	431 269 F	-
40.0	G 2	-	230 V 50 Hz	3002	0 - 64	-	103.0	-	8.50	-	431 296 K

* 64 bar versions on request

Customized System Solutions

Customized System Solutions

Valve Program



INGENIEROS ASOCIADOS DE CONTROL S.L.
Telf.: 913831390
comercial@iac-sl.es

Sensor Program



Accessories & Pneumatics

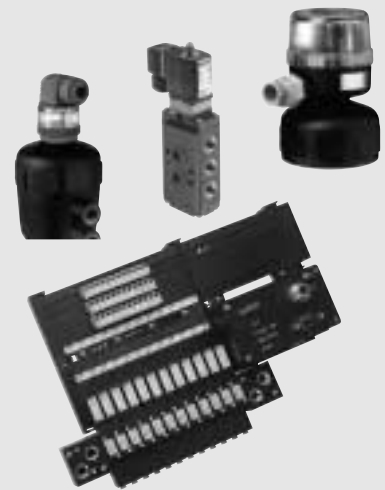

Burkert offers a wide range
of system solutions

- Flow Control
- Analytical Control
- Temperature Control
- Level Control
- Pressure Control



Please contact us for
more informations.