

2/2-Way, Stainless Steel, DN 15-50 mm, PN10



Advantages / Benefits

- ▶ Integrated, cascaded process controller with parameter definable PID-algorithm
- ▶ Body material: forged stainless steel in various surface finishes
- ▶ Steam sterilizable
- ▶ Automatic self-adjustment of basic parameters
- ▶ User-friendly operation - menu-guided
- ▶ Code-protection against unauthorized access
- ▶ Fluid is hermetically isolated from the actuator by the diaphragm
- ▶ CE certified

Design

This continuous control system is a combination of a piston operated diaphragm valve with stainless steel body, a position sensor and an electro-pneumatic control system. The position sensor measures the actual regulating distance of the valve.

The microprocessor controlled electronics continuously compares this actual value to a controller output, pre-defined by the standard signal input. In case of a control difference, the electro-pneumatic control system corrects the control position. Due to the 4...20 mA standard transmitter input the positioner can also be used as a cascaded process controller for controlled variables such as flow, temperature, pressure, level etc. The diaphragm between the actuator and body of the valve hermetically isolates the fluid from the actuator.

- Programmable flow curves:
 - linear, equal percentage
 - freely programmable via restart points
- No control air consumption in stabilized condition
- Excellent flow characteristic combined with high flow rates

Applications

Fluids

Ultra-pure, sterile, aggressive, abrasive or high viscosity fluids up to 140 °C.

Applications

- Pharmaceutical
- Process technology
- Biotechnology
- Systems engineering
- Cosmetic and food industry
- Bottling systems



INGENIEROS ASOCIADOS DE CONTROL S.L.

Tel.: 913831390
comercial@iac-sl.es

burkert
Easy Fluid Control Systems

Technical Data Positioner Type 1067

Electrical Data

Voltage supply:	24 V DC
Power consumption:	< 10 W
Signal input for positioner:	Unit signal: 4 ... 20 mA 0 ... 20 mA 0 ... 10 V
Binary input:	Configurable as normally open or closed contact.
Connection:	Clamping screw 1,5 mm Cable gland 2 x PG 9

Pneumatic Data

Instrument air:	Air, filtered compressed air, lubricated or non-lubricated
Pressure range:	0 ... 6 bar
Air performance	
Air inlet valve:	33 (66) NI/min ⁽¹⁾
Exhaust valve:	38 (76) NI/min ⁽¹⁾
	⁽¹⁾ In case of pressure drop from 6 to 5 bar. (Figures in brackets as option).
Internal air consumption in leveled status:	0 NI/min
Connection:	Internal screw thread G 1/8"

Installation and Operation Data

Overall dimensions of positioner	(B x H x T): 125 mm x 80 mm x 77 mm
Body material:	Aluminium, laquered
Fluid plate material:	Aluminium, anodized
Weight of positioner:	approx. 1 kg
Rating:	IP 65
Operating temperature:	0 ... 60 °C

Technical Data Control Valve 2031

Valve

Size (DN):	15, 20, 25, 40, 50
Rangeability:	Control range $\geq 50:1$
Flow features:	Modified equal percentage
Flow capacity:	see table page 4
Medium temperature:	-10°C...+140°C
Max. Operating pressure:	10 bar (at ambient temperature)

Actuator

Actuator size (ø mm):	see table page 3
Signal (bar):	Air min. 5.5 bar, air max. 7 bar
Function:	Normally closed under spring force.

Functional Diagram

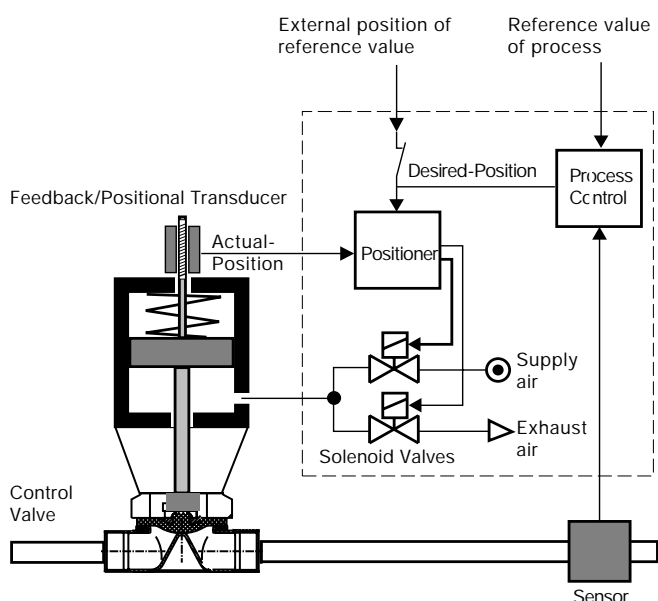

Material

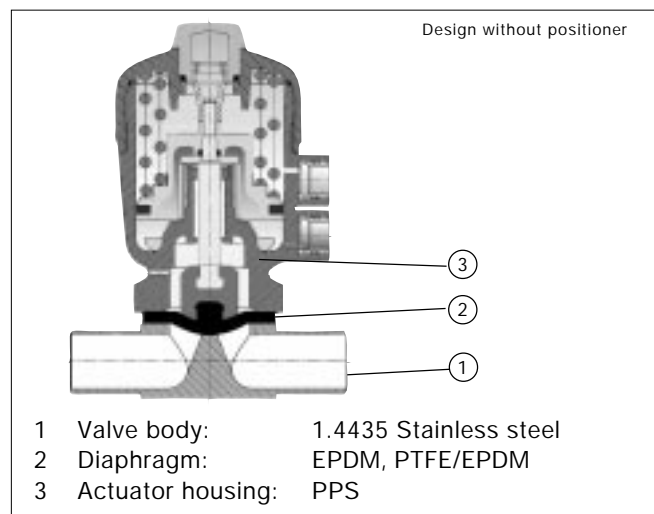

Ordering Chart

Weld end connection

Orifice DN [mm]	Port-size	Act. size [mm]	Oper. press. [bar]	Item-No.	Item-No.
				glass beaded/ satin finish	electropol./ electropol.
Ra (ext.)				<2.0max.,ø1.6	<1.0max.,ø0.8
Ra (int.)				<0.9max.,ø0.6	<0.5max.,ø0.3
15	21.3 x 1.6	63	10.0	423 528 K	426 134 B
		63	10.0	423 529 L	426 135 C
20	26.9 x 1.6	80	10.0	423 531 E	426 137 E
		80	10.0	423 532 F	426 138 P
25	33.7 x 2.0	80	10.0	423 533 G	426 139 Q
		80	8.0	423 534 H	426 140 V
40	48.3 x 2.0	125	10.0	423 536 B	426 142 K
		125	10.0	423 537 C	426 143 L
50	60.3 x 2.0	125	8.0	423 538 M	426 144 M
		125	7.0	423 539 N	426 145 N

TriClamp® connection

Port-size	Item-No.	Item-No.	Item-No.
	glass beaded/ satin finish	glass beaded/ mirror finish	electropol./ electropol.
	<2.0max.,ø1.6	<2.0max.,ø1.6	<1.0max.,ø0.8
	<0.9max.,ø0.6	<0.4max.,ø0.1	<0.5max.,ø0.3
18.1	423 540 T	426 122 F	426 146 P
18.1	423 541 Q	426 123 G	426 147 Q
23.7	423 543 J	426 125 A	426 149 S
23.7	423 544 K	426 126 B	426 150 X
29.7	423 392 K	426 127 C	426 151 L
29.7	423 545 L	426 128 M	426 152 M
44.3	423 547 N	426 130 K	426 154 P
44.3	423 548 X	426 131 G	426 155 Q
56.3	423 549 Y	426 132 H	426 156 R
56.3	423 550 V	426 133 A	426 157 J

Seal (Diaphragm)	Weight [kg]
EPDM	2.0
PTFE/EPDM	2.0
EPDM	3.0
PTFE/EPDM	3.0
EPDM	3.2
PTFE/EPDM	3.2
EPDM	6.8
PTFE/EPDM	6.8
EPDM	8.6
PTFE/EPDM	8.6

Easy Pressure Control Flow Control Temperature Control

Easy to commission

Automatic self-adjustment of basic parameters by finger tip control

Easy to install

- Compact design
- Delivered pre-mounted, tested and ready to install
- Requires less space than conventional control valves

Easy to operate

- User-friendly operation
- LCD and key pad
- Menue guided access
- Programmable characteristic curves

Easy to operate



Burkert control valve with Burkert digital flow transmitter for continuous process control.



Burkert
Link

Specifications - Flow Capacity

Plug travel [%]	Kv-value [water m ³ /h]				
	DN15	DN20	DN25	DN40	DN50
0	0.00	0.00	0.00	0.00	0.00
10	0.05	0.10	0.28	0.60	2.80
20	0.20	0.40	1.20	3.10	5.30
30	0.50	1.20	2.50	7.10	9.50
40	1.10	2.30	5.40	14.20	18.30
50	1.80	3.20	8.60	20.10	30.10
60	2.80	4.60	10.60	26.80	38.60
70	3.80	5.90	11.90	32.10	44.50
80	4.60	6.70	12.70	34.50	48.60
90	4.90	6.90	12.90	34.70	51.80
100	5.00	7.00	13.00	34.80	52.00

Dimensions [mm]

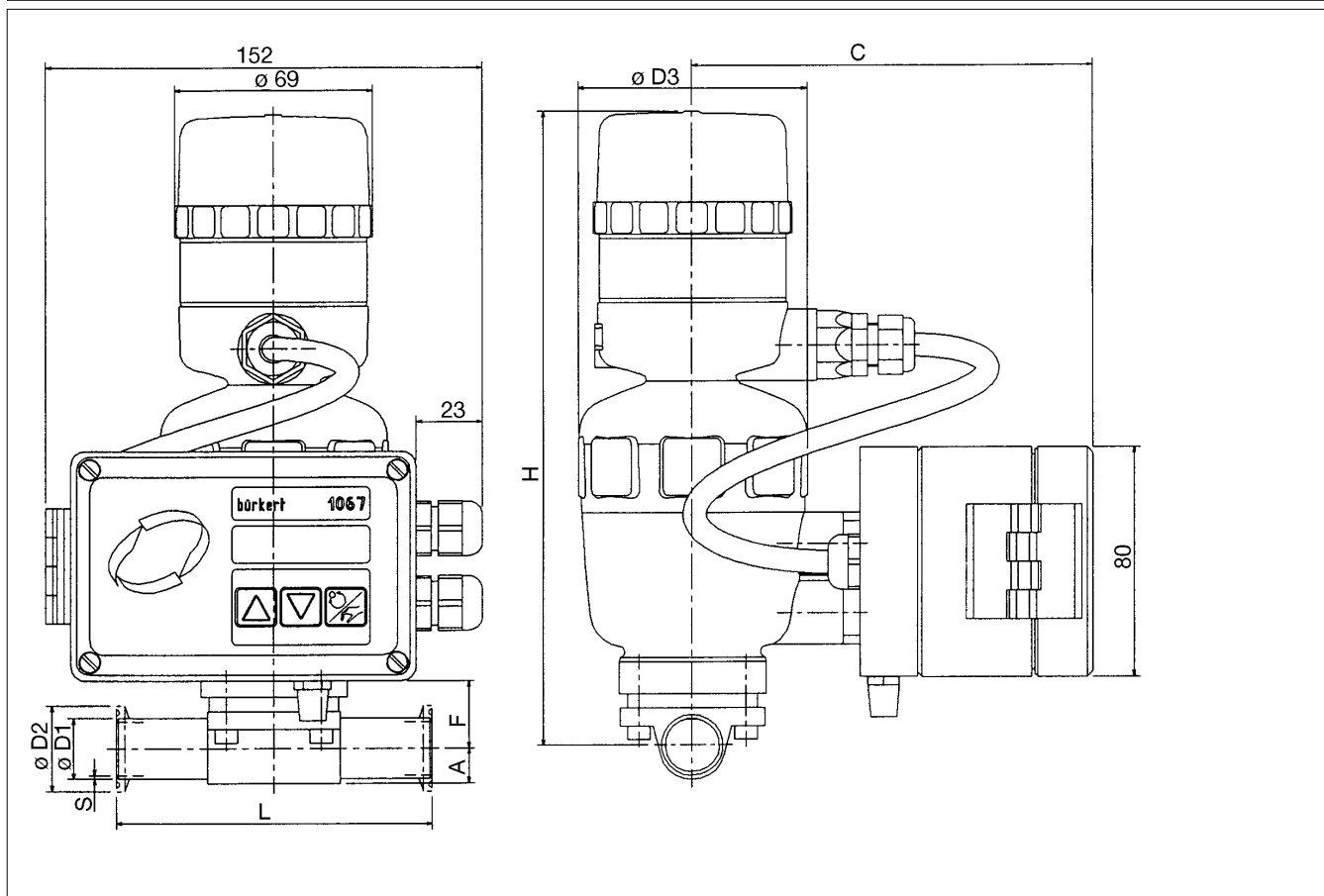

Variable dimensions [mm]

DN	Actuator size	A	C	øD1	øD2	øD3	F	H	L	S
15	63	11	139	21.3	25.0	80	21	230	110	1.6
20	80	16	147	26.9	25.0	101	40	267	119	1.6
25	80	18	147	33.7	50.5	101	43	250	129	2.0
40	125	27	173	48.3	50.5	127	63	366	161	2.0
50	125	33	173	60.3	64.0	153	71	372	192	2.0

