

Resistance Thermometers

with Thread • Model TR201

Electronic Temperature Measurement

Services intended

- Machinery, plant and tank construction
- Energy and power station engineering
- Process industry
- Petroleum industry
- Heating, air conditioning and ventilation industry

General

Resistance thermometers in this series are designed for direct screw fitting into the process, mainly in tanks and pipelines.

These temperature probes are suitable for fluid and gaseous media under moderate mechanical load and normal chemical stress. The thermowell made of stainless steel is fully welded and screw-fitted into the connection head.

The exchangeable measuring insert can be dismantled without removing the complete probe from the process. This makes inspection and replacement when servicing is necessary, during operation possible while the plant is running. Selection of normal or standard length enables short delivery time and the possibility of stocking spare components.

Insertion length, process connection, design of thermowell, connection head and sensor can be selected individually for the respective application.

Intrinsically safe designs are available for applications in hazardous areas. The model series TR201 is provided with a conformity certificate for "intrinsically safe" type of protection to EEx ib IIC T6. Manufacturer's certification to NAMUR NE 24 or in accordance with DIN VDE 0165, respectively, is also available.

Optional installation of analogue or digital transmitters completes the range of applications.

- (- analogue, fixed measuring ranges:
 - Model T20 to data sheet TE 20.01,
- analogue, measuring range selectable with soldered bridges:
 - Model T21 to data sheet TE 21.01,
- analogue, process industry series:
 - Model T31 to data sheet TE 31.01,
- digital, Model T12 to data sheet TE 12.01,
- digital, with HART® Protocol: Model T32 to data sheet TE 32.01)

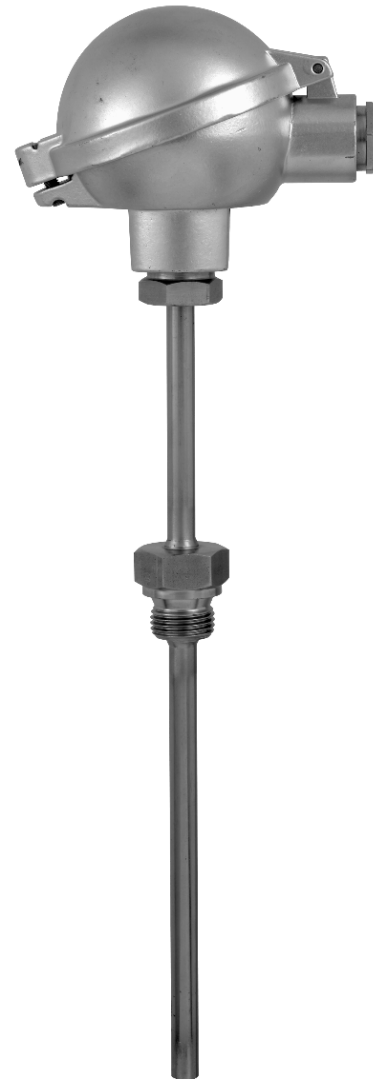

TR201 components

- ① Connection head
- ② Thermowell
- ③ Process connection
- ④ Measuring insert
- ⑤ Transmitter (optional)
- ⑥ Neck

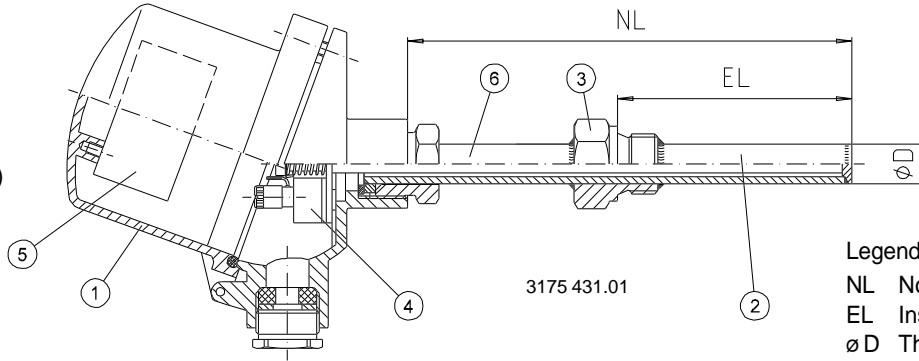

Legend:
 NL Nominal length
 EL Insertion length
 $\varnothing D$ Thermowell diameter

Thermowell

These thermowells are made of drawn tube with welded bottom and screwed into the connection head. The cable entry of the connection head can be aligned.

The process connection is welded onto the thermowell in the factory to customer's own specifications. This also determines the insertion length. Preference is to be given to standard nominal lengths or insertion lengths to DIN Standards, respectively.

Designs to DIN Standards as well as special designs (for example, with tapered thermowell, reinforced extension neck, etc.) are available in stainless steel 1.4571 or special materials.

Nominal length and insertion length to DIN 43 763

Form	Nominal length	Insertion length
B1 / C1	290 mm	160 mm
B2 / C2	380 mm	250 mm
B3 / C3	530 mm	400 mm
G1, quick response	292 mm	160 mm
G2, quick response	352 mm	220 mm
G3, quick response	412 mm	280 mm

Design of thermowell

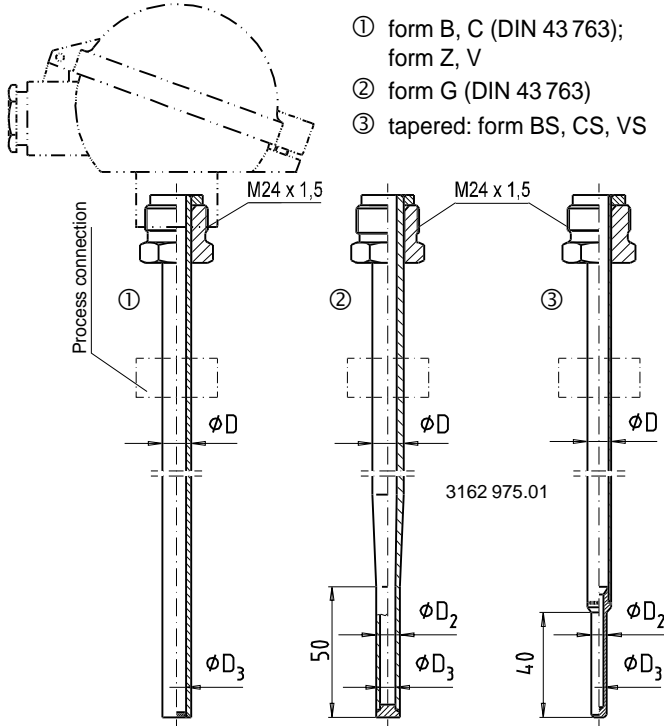

Standard nominal lengths

250, 290, 350, 380, 410, 500, 530, 630, 710, 1000 mm
 other on request

Material

Stainless steel 1.4571
 other on request

Dimensions

Form	Dimensions in mm		
	outer diameter	outer diameter at tip	inner diameter at tip
	D	D ₂	D ₃
B	9 ¹⁾	—	7
C	11 ¹⁾	—	7
Z	12	—	7
V	14	—	9
G	12	9	6.1
BS	9 ¹⁾	6	3.5
CS	11 ¹⁾	6	3.5
VS	14	9	6.5

1) with reinforced extension neck: 14 mm in neck area

Connection head

Model	Material	Cable entry		Degree of protection	Cover closure	Surface finish
		standard	with adapter			
BS	Aluminium	Pg 16	Pg 13.5 ½ NPT	IP 54	cover with 2 screws	silver bronze, painted
BSZ	Aluminium	Pg 16	Pg 13.5 ½ NPT	IP 65	flap cover ¹⁾	silver bronze, painted
BSZ-H	Aluminium	Pg 16	Pg 13.5 ½ NPT	IP 65	flap cover ¹⁾	silver bronze, painted
BSS	Aluminium	Pg 16	Pg 13.5 ½ NPT	IP 65	flap cover ²⁾	silver bronze, painted
BSS-H	Aluminium	Pg 16	Pg 13.5 ½ NPT	IP 65	flap cover ²⁾	silver bronze, painted
BSK	Plastic	Pg 16	Pg 13.5 ½ NPT	IP 54	screw cover	black
BSK-H	Plastic	Pg 16	Pg 13.5 ½ NPT	IP 54	screw cover	black
BVA	stainless steel	Pg 16	Pg 13.5 ½ NPT	IP 65	screw cover	blank
BUK-H	Polyamide	Pg 13.5		IP 65	flap cover ¹⁾	beige ³⁾

1) with screw

2) with clip

3) designs with explosion protection: black

Process connection

Process connection: see table

- Design:
- male thread, welded with thermowell
 - union nut
 - compression fitting, only with thermowell diameter 12 mm and 14 mm
(Compression fittings allow simple adaptation to the required insertion length at the installation point. After tightening, the compression fitting can no longer be moved on the thermowell.)

Material: stainless steel 1.4571
other on request

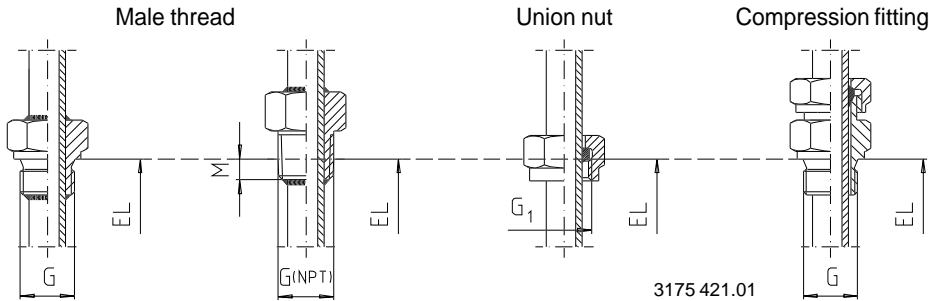

Legend:

- EL Insertion length
- G Male thread
- G₁ Female thread
- M Screw-in length by hand,
- with ½ NPT approx. 8.1 mm
- with ¾ NPT approx. 8.6 mm

Possible combinations: process connection and thermowell diameter

Process connection	Extension neck diameter			
	9 mm	11 mm	12 mm	14 mm
Male thread	G ½ A	G ½ A	G ½ A	G ½ A
	–	G 1 A	G 1 A	G 1 A
	M 20 x 1.5	M 20 x 1.5	M 20 x 1.5	M 20 x 1.5
	½ NPT	½ NPT	½ NPT	½ NPT
Union nut	G ½	G ½	G ½	–
	–	G ¾	G ¾	G ¾
	M 24 x 1.5	M 24 x 1.5	M 24 x 1.5	M 24 x 1.5
	M 27 x 2	M 27 x 2	M 27 x 2	M 27 x 2
Compression fitting	–	–	G ½ A	G ½ A

Sensor

The sensor is located in the measuring insert, which is exchangeable and spring loaded (spring travel: max. 10 mm). The measuring insert fitted is a tube design (Model TR001 to data sheet TE 60.01) or a sheathed cable design (Model TR002 to data sheet TE 60.01).

Should servicing be necessary the following applies for the required replacement measuring insert:

Measuring insert length = nominal length of thermometer + 25 mm
Measuring insert diameter: depending on form of thermowell, see table

The diameter of the measuring insert – and thus the thermowell – limits the number of sensors and their method of connection.

Where 2 wire connection is concerned, inner wiring resistance appears as fault in the measurement. Therefore, probes with standard accuracy (limiting error, Class B) should not exceed 1000 mm of nominal length with 6 mm diameter measuring insert (or 350 mm with a 3 mm diameter measuring insert). 3 or 4 wire connection should be selected for longer lengths or improved accuracy.

Thermowell		Measuring insert diameter in mm	Sensor / Sensor method of connection						
form	inner diameter at tip in mm		1 x Pt 100			2 x Pt 100			3 x Pt 100
			2 wire	3 wire	4 wire	2 wire	3 wire	4 wire	2 wire
BS, CS	3.5	3	x	x	x	x	–	–	–
B, C, Z	7	6	x	x	x	x	x	x ¹⁾	x
G	6.1	6	x	x	x	x	x	x ¹⁾	x
VS	6.5	6	x	x	x	x	x	x ¹⁾	x
V	9	8	x	x	x	x	x	x ¹⁾	x

1) always measuring insert model TR002, sheathed cable design

Sensor limiting error

- Class A to DIN EN 60751 (only with 3 wire or 4 wire method of connection)
- Class B to DIN EN 60751
- ½ DIN B at 0 °C

Terminal appropriation and marking

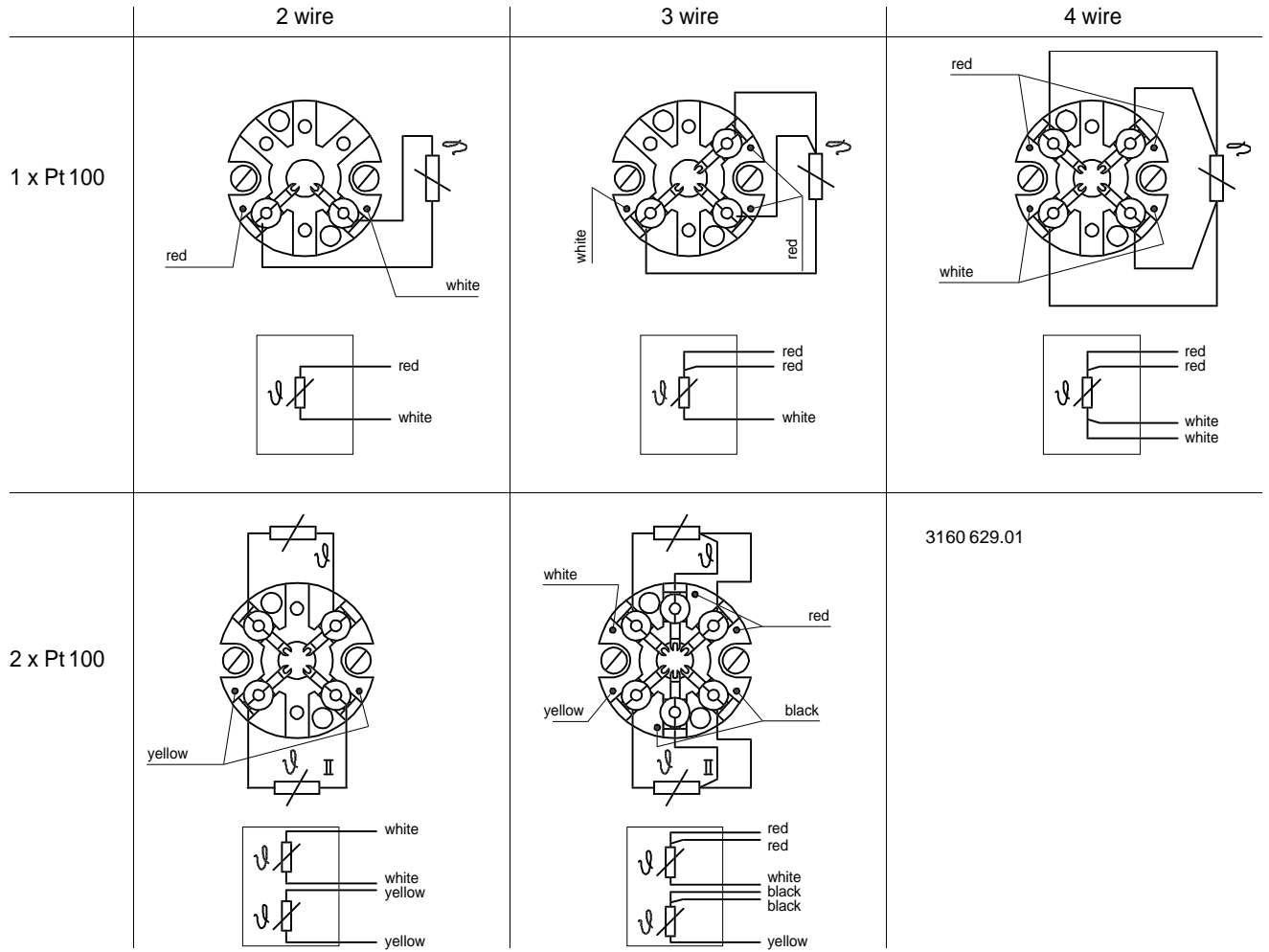

Transmitter (optional)

A transmitter can be fitted directly in the probe. As a general rule two installation versions are possible. Two transmitter installation on request.

Installation on measuring insert

The transmitter is fastened directly on the measuring insert instead of the connection socket. This version of installation is used in the case of connection heads with low cover.

Installation in connection head cover

The main advantage of this version of installation is the use of a standard measuring insert and thus easy to obtain spare parts should servicing be necessary. This version of installation needs connection heads with high cover: model BSZ-H, BSS-H, BSK-H and BUK-H.

Model	Description	Explosion protection	Data sheet
T20	analogue transmitter with fixed measuring range	optional	TE 20.01
T21	analogue transmitter, measuring range selectable with soldered bridges	without	TE 21.01
T31	analogue transmitter, process industry series	optional	TE 31.01
T12	digital transmitter, configurable	optional	TE 12.01
T32	digital transmitter with HART-Protocol, configurable	optional	TE 32.01

Explosion protection (optional)

- Temperature probes to DIN EN 50 014 / DIN EN 50 020 in accordance with CENELEC with a conformity certificate for "intrinsically safe" type of protection to EEx ib IICT6 are approved for use in Zone 1.
The thermowell separates Zone 0 from Zone 1. This presupposes thermowells comply with the plant design regulations with regard to corrosion resistance, mechanical strength and wall thickness. The selection of a suitable thermowell is the responsibility of the user.
Fitted transmitters have their own conformity certificate.

- Temperature probes with measuring insert to NAMUR NE 24 are certified with manufacturer's certification for Ex i application. The suitability of the thermowell for the appropriate explosion zone is not covered in NAMUR NE 24.
- Temperature probes deviating in design from the conformity certificate can then be certified with manufacturer's certification for Ex i application if these probes fulfil the requirements to DIN VDE 0165/2.91. Such certified probes must only be used in Zone 1 and Zone 2.

Order code for resistance thermometer with thread Model TR201

Field No.	Code	Instrument design
		Explosion protection
	Z	without
	X	EEx ib IIC T6 to PTB No. Ex-97.D.2006 X
	B	intrinsically safe with manufacturer's certification to NAMUR NE 24
1	C	intrinsically safe with manufacturer's certification, DIN VDE 0165
		Type and number of sensors
	1	1 x Pt 100 application range -50 ... +250 °C
	2	2 x Pt 100 application range -50 ... +250 °C
	3	1 x Pt 100 application range -200 ... +600 °C
	4	2 x Pt 100 application range -200 ... +600 °C
	5	1 x Pt 100 enhanced vibration protection, application range -50 ... +400 °C
	6	2 x Pt 100 enhanced vibration protection, application range -50 ... +400 °C
2	?	other
		Sensor limiting error
	A	Class A to DIN EN 60751
	B	Class B to DIN EN 60751
	C	1/3 DIN B at 0 °C
3	?	other
		Sensor method of connection
	1	2 wire <i>not with sensor limiting error, Class A</i>
	2	3 wire
4	3	4 wire
		Process connection
	GD	G 1/2 A
	GF	G 1 A
	MM	M 27 x 2
	ND	1/2 NPT
5	??	other
		Design of process connection
	G	male thread
	U	union nut
6	K	compression fitting, G 1/2 A, stainless steel <i>for thermowell diameter 12 mm or 14 mm</i>
		Process connection material
	1	stainless steel 1.4571
7	?	other
		Thermowell diameter
	4	9 mm
	6	11 mm
	7	12 mm
	B	9 mm, tapering to 6 mm
	C	11 mm, tapering to 6 mm
8	?	other
		Nominal length
	290	290 mm <i>insertion length and form design, see page 2</i>
	380	380 mm <i>insertion length and form design, see page 2</i>
	530	530 mm <i>insertion length and form design, see page 2</i>
	292	292 mm <i>insertion length and form design, see page 2</i>
	352	352 mm <i>insertion length and form design, see page 2</i>
	412	412 mm <i>insertion length and form design, see page 2</i>
		enter length in mm to max. 999 mm, enter as three digits e.g. 317 for 317 mm
9	???	length greater than 999 mm <i>please state as additional text</i>
		Insertion length
		enter length in mm to max. 999 mm, enter as three digits e.g. 088 for 88 mm
10	???	length greater than 999 mm <i>please state as additional text</i>
		Thermowell material
	1	stainless steel 1.4571
11	?	other

1) maximum insertion length: nominal length minus 60 mm

Field No.	Code	Instrument design
		Connection head
	1	model BS
	2	model BSZ
	3	model BSZ-H
	4	model BSS
	5	model BSS-H
	6	model BSK
	7	model BSK-H
	8	model BVA
12	<input type="checkbox"/>	? other
		Cable entry to connection head
	1	Pg 16
	2	Pg 13.5
	3	1/2 NPT
13	<input type="checkbox"/>	? other
		Transmitter
	ZZ	without
	A0	model T20, without explosion protection <i>sensor method of connection 4 wire is not connectable</i>
	A2	model T20, with explosion protection EEx ia <i>sensor method of connection 4 wire is not connectable</i>
	A4	model T20, with explosion protection EEx ib <i>sensor method of connection 4 wire is not connectable</i>
	B0	model T21, without explosion protection <i>sensor method of connection 4 wire is not connectable</i>
	C2	model T31, with explosion protection EEx ia <i>sensor method of connection 4 wire is not connectable</i>
	C4	model T31, with explosion protection EEx ib <i>sensor method of connection 4 wire is not connectable</i>
	D0	model T12, without explosion protection <i>configured to customer specification</i>
	D2	model T12, with explosion protection EEx ia <i>configured to customer specification</i>
	D4	model T12, with explosion protection EEx ib <i>configured to customer specification</i>
	E0	model T32, without explosion protection <i>configured to customer specification</i>
	E2	model T32, with explosion protection EEx ia <i>configured to customer specification</i>
	E4	model T32, with explosion protection EEx ib <i>configured to customer specification</i>
14	<input type="checkbox"/>	?? other
		Transmitter measuring range
	ZZ	without
	KK	customer's specification <i>only transmitter model: T12, T32 please use sheet "help to order"</i>
		standard range <i>only transmitter model: T20, T21, T31 code see price list</i>
15	<input type="checkbox"/>	?? special range <i>only transmitter model: T20, T21, T31 please state as additional text</i>
		Quality Assurance Documentation
	Z	without
16	<input type="checkbox"/>	1 with <i>Please state in clearly understandable text !</i>
		Additional order details
	YES	NO
17	<input type="checkbox"/>	T Z additional text <i>Please state in clearly understandable text !</i>

Order code for Model TR201

	1	2	3	4	5	6	7	8	9	10	11	12	13	14	15	16	17		
TR201	-	<input type="checkbox"/>	-	<input type="checkbox"/>	<input type="checkbox"/>	<input type="checkbox"/>	-	<input type="checkbox"/>	-	<input type="checkbox"/>	<input type="checkbox"/>	<input type="checkbox"/>	<input type="checkbox"/>	<input type="checkbox"/>	<input type="checkbox"/>	<input type="checkbox"/>	<input type="checkbox"/>	-	<input type="checkbox"/>

Additional text: _____

Specifications and dimensions given in this leaflet are correct at the time of printing.
Modifications may take place and materials specified may be replaced by others without prior notice.



INGENIEROS ASOCIADOS DE CONTROL S.L.

Tel: 913831390
comercial@iac-sl.es